



Internal Use Only

<http://biz.lgservice.com>

Room Air Conditioner SVC MANUAL(General)

MODEL : General Wall Mounted-Inverter Type

CAUTION

Before Servicing the unit, read the safety precautions in General SVC manual.
Only for authorized service personnel.

CONTENTS

| | | |
|---------------|---|----|
| Part 1 | General Information | |
| 1. | Safety Precautions..... | 4 |
| 2. | Nomenclature | 7 |
| Part 2 | Functions & Controls | |
| 1. | List of Functions & Controls..... | 9 |
| 2. | Basic Mode Controls | 10 |
| 3. | Special Mode Controls | 12 |
| 4. | Utility Functions | 13 |
| Part 3 | Test Run | |
| 1. | Check before Test Run | 17 |
| 2. | Test Run Flow chart | 18 |
| 3. | Test Run Detail | 19 |
| Part 4 | Trouble Shooting Guide | |
| 1. | 2-Way, 3-Way Valve | 21 |
| 2. | Pumping Down | 22 |
| 3. | Evacuation (All amount of refrigerant leaked) | 23 |
| 4. | Gas Charging (After Evacuation) | 24 |
| 5. | Cycle Troubleshooting Guide | 25 |
| 6. | Electric Parts Troubleshooting Guide..... | 26 |
| 7. | Self-diagnosis Function | 30 |



Part 1 General Information

| | |
|-----------------------------|---|
| 1. Safety Precautions | 4 |
| 2. Nomenclature..... | 7 |



1. Safety Precautions

To prevent injury to the user or other people and property damage, the following instructions must be followed.







- Incorrect operation due to ignoring instruction will cause harm or damage. The seriousness is classified by the following indications.





| | |
|--|---|
|  WARNING | This symbol indicates the possibility of death or serious injury. |
|  CAUTION | This symbol indicates the possibility of injury or damage to properties only. |

- Meanings of symbols used in this manual are as shown below.







| | |
|---|---|
|  | Be sure not to do. |
|  | Be sure to follow the instruction. |
|  | Dangerous Voltage |

1.1 Cautions in Repair





|  WARNING | |
|--|--|
|  | Be sure to disconnect the power cable plug from the plug socket before disassembling the equipment for a repair. Internal components and circuit boards are at main potential when the equipment is connected to the power cables. This high voltage is extremely dangerous and may cause death or severe injury if come in contact with it. |
|  | Do not touch the discharging refrigerant gas during the repair work. The discharging refrigerant gas. The refrigerant gas can cause frostbite. |
|  | Release the refrigerant gas completely at a well-ventilated place first. Otherwise, when the pipe is disconnected, refrigerant gas or refrigerating machine oil discharges and it Can cause injury. |
|  | When the refrigerant gas leaks during work, perform ventilation. If the refrigerant gas comes in contact with a fire, poisonous gas generates. A case of leakage of the refrigerant and the closed room full with gas is dangerous because a shortage of oxygen occurs. Be sure to perform ventilation. |
|  | When removing the front panel or cabinet, execute short-circuit and discharge between high voltage capacitor terminals. If discharge is not executed, an electric shock is caused by high voltage resulting in a death or injury. |
|  | Do not turn the air-conditioner ON or OFF by plugging or unplugging the power plug. There is risk of fire or electrical shock. |





| | |
|---|--|
|  | <p>Do not use a defective or underrated circuit breaker. Use the correctly rated breaker and fuse. Otherwise there is a risk of fire or electric shock.</p> |
|  | <p>Install the panel and the cover of control box securely. Otherwise there is risk of fire or electric shock due to dust, water etc.</p> |
|  | <p>Indoor/outdoor wiring connections must be secured tightly and the cable should be routed properly so that there is no force pulling the cable from the connection terminals. Improper or loose connections can cause heat generation or fire.</p> |
|  | <p>Do not touch, operate, or repair the product with wet hands. Holding the plug by hand when taking out. Otherwise there is risk of electric shock or fire.</p> |

⚠ CAUTION

| | |
|---|--|
|  | <p>Do not turn on the breaker when the front panel and cabinet are removed.</p> |
|  | <p>Be sure to ground the air conditioner with an earthing conductor connected to the earthing terminal.</p> |
|  | <p>Conduct repair works after checking that the refrigerating cycle section has cooled down sufficiently. Otherwise, working on the unit, the hot refrigerating cycle section can cause burns.</p> |
|  | <p>Do not tilt the unit while removing panels. Otherwise, the water inside the unit can spill and wet floor.</p> |
|  | <p>Do not use the welder in a well-ventilated place. Using the welder in an enclosed room can cause oxygen deficiency.</p> |
|  | <p>Be sure to turn off power switch before connecting or disconnecting connector, or parts damage may be occur.</p> |

1.2 Inspections after Repair

| ⚠ WARNING | |
|---|--|
|  | Check to see if the power cable plug is not dirty or loose. If the plug is dusty or loose it can cause an electrical shock or fire. |
|  | Do not use a joined power cable or extension cable, or share the same power outlet with other electrical appliances. otherwise, it can cause an electrical shock, excessive heat generation or fire. |
|  | Do not insert hands or other objects through the air inlet or outlet while the product is operating. There are sharp and moving parts that could cause personal injury. |
|  | Do not block the inlet or outlet of air flow. It may cause product failure |

| ⚠ CAUTION | |
|---|--|
|  | Check to see if the parts are mounted correctly and wires are connected. Improper installation and connections can cause an electric shock or an injury. |
|  | Check whether the installation platform or frame has corroded. Corroded installation platform or frame can cause the unit to fall, resulting in injury. |
|  | Be sure to check whether the earth wire is correctly connected. |
|  | After the work has finished, be sure to do an insulation test to check whether the resistance is 2[Mohm] or more between the charge section and the non-charge metal section (Earth position). If the resistance value is low, a disaster such as a leak or electric shock is caused at user's side. |
|  | Check the drainage of the indoor unit after the repair. If drainage is faulty the water may enter the room and wet floor. |

2. Nomenclature

2.1 Global Model Name

| | | | | | | | | | | |
|----------|----------|---|----------|----------|----------|----------|----------|----------|----------|----------|
| A | S | - | W | 1 | 2 | 6 | B | M | S | 0 |
| 1 | 2 | - | 3 | 4 | 5 | 6 | 7 | 8 | 9 | 10 |

| Code | Type | Code of Model | Meaning | | | | | | | | | | | | | | | | | | | | | | | | | | | | | | | | | | | | | | |
|--|-----------------------------------|---------------|---|-------|---|------------|---|--------------------------------|---|---|---|--|---|------------------------------------|---|---|---|------------------------------|---|-----------------------------------|---|----------------------------------|---|---|---|---|---|-----------------------|---|--|---|--------------------------------|---|-----------------------|---|-----------------------|---|---------------------|---|----------------------------|---|
| 1 | Production Center, Refrigerant | A~Z | L: Chang-won R22 A: Chang-won R410A | | | | | | | | | | | | | | | | | | | | | | | | | | | | | | | | | | | | | | |
| 2 | Product Type | A~Z | S: Split Type Air Conditioner | | | | | | | | | | | | | | | | | | | | | | | | | | | | | | | | | | | | | | |
| 3 | Cooling/Heating/Inverter | A~Z | C: Cooling Only H: Heat Pump X: C/O + E/Heater Z: H/P + E/Heater V: AC Inverter C/O N: AC Inverter H/P Q: DC Inverter C/O W: DC Inverter H/P | | | | | | | | | | | | | | | | | | | | | | | | | | | | | | | | | | | | | | |
| 4, 5 | Capacity | 0~9 | Cooling/Heating Capacity Ex. "09" → 9,000 Btu/h | | | | | | | | | | | | | | | | | | | | | | | | | | | | | | | | | | | | | | |
| 6 | Electric Range | 1~9 A~Z | 1: 115V/60Hz 2: 220V/60Hz 3: 208-230V/60Hz 5: 200-220V/50Hz 6: 220-240V/50Hz 7: 110V, 50/60Hz | | | | | | | | | | | | | | | | | | | | | | | | | | | | | | | | | | | | | | |
| 7 | Chassis | A~Z | Name of Chassis | | | | | | | | | | | | | | | | | | | | | | | | | | | | | | | | | | | | | | |
| 8 | Look | A~Z | Look, Color (Artcool Model) | | | | | | | | | | | | | | | | | | | | | | | | | | | | | | | | | | | | | | |
| 9 | Function | A~Z | <table border="1"> <tbody> <tr><td>Basic</td><td>A</td></tr> <tr><td>Basic+4Way</td><td>B</td></tr> <tr><td>Basic + Filter (Carbon filter)</td><td>C</td></tr> <tr><td>Plasma+(A/changeove)+A/clean+2Way + Ion</td><td>E</td></tr> <tr><td>Plasma+(A/changeove)+A/clean+4way + Ion + Lamp</td><td>F</td></tr> <tr><td>Plasma+(A/changeove)+A/clean+Low A</td><td>G</td></tr> <tr><td>Plasma+(A/changeove)+A/clean+4way+Low A</td><td>H</td></tr> <tr><td>Plasma+(A/changeove)+A/clean</td><td>L</td></tr> <tr><td>Plasma+(A/changeove)+A/clean+4way</td><td>M</td></tr> <tr><td>Plasma+(A/changeove)+A/clean+PTC</td><td>N</td></tr> <tr><td>Plasma+(A/changeove)+Autoclean+4way+PTC</td><td>P</td></tr> <tr><td>Plasma+(A/changeove)+A/clean+4way+Low A+PTC</td><td>Q</td></tr> <tr><td>Smart(Robot) Cleaning</td><td>R</td></tr> <tr><td>Eco eye + Plasma + Allergy Filter + 4way</td><td>S</td></tr> <tr><td>Plasma + Allergy Filter + 4way</td><td>U</td></tr> <tr><td>Allergy Filter + 4way</td><td>V</td></tr> <tr><td>Allergy Filter + 2way</td><td>W</td></tr> <tr><td>Basic + Low Ambient</td><td>Y</td></tr> <tr><td>Basic+(A/clean)+4way+Low A</td><td>Z</td></tr> </tbody> </table> | Basic | A | Basic+4Way | B | Basic + Filter (Carbon filter) | C | Plasma+(A/changeove)+A/clean+2Way + Ion | E | Plasma+(A/changeove)+A/clean+4way + Ion + Lamp | F | Plasma+(A/changeove)+A/clean+Low A | G | Plasma+(A/changeove)+A/clean+4way+Low A | H | Plasma+(A/changeove)+A/clean | L | Plasma+(A/changeove)+A/clean+4way | M | Plasma+(A/changeove)+A/clean+PTC | N | Plasma+(A/changeove)+Autoclean+4way+PTC | P | Plasma+(A/changeove)+A/clean+4way+Low A+PTC | Q | Smart(Robot) Cleaning | R | Eco eye + Plasma + Allergy Filter + 4way | S | Plasma + Allergy Filter + 4way | U | Allergy Filter + 4way | V | Allergy Filter + 2way | W | Basic + Low Ambient | Y | Basic+(A/clean)+4way+Low A | Z |
| Basic | A | | | | | | | | | | | | | | | | | | | | | | | | | | | | | | | | | | | | | | | | |
| Basic+4Way | B | | | | | | | | | | | | | | | | | | | | | | | | | | | | | | | | | | | | | | | | |
| Basic + Filter (Carbon filter) | C | | | | | | | | | | | | | | | | | | | | | | | | | | | | | | | | | | | | | | | | |
| Plasma+(A/changeove)+A/clean+2Way + Ion | E | | | | | | | | | | | | | | | | | | | | | | | | | | | | | | | | | | | | | | | | |
| Plasma+(A/changeove)+A/clean+4way + Ion + Lamp | F | | | | | | | | | | | | | | | | | | | | | | | | | | | | | | | | | | | | | | | | |
| Plasma+(A/changeove)+A/clean+Low A | G | | | | | | | | | | | | | | | | | | | | | | | | | | | | | | | | | | | | | | | | |
| Plasma+(A/changeove)+A/clean+4way+Low A | H | | | | | | | | | | | | | | | | | | | | | | | | | | | | | | | | | | | | | | | | |
| Plasma+(A/changeove)+A/clean | L | | | | | | | | | | | | | | | | | | | | | | | | | | | | | | | | | | | | | | | | |
| Plasma+(A/changeove)+A/clean+4way | M | | | | | | | | | | | | | | | | | | | | | | | | | | | | | | | | | | | | | | | | |
| Plasma+(A/changeove)+A/clean+PTC | N | | | | | | | | | | | | | | | | | | | | | | | | | | | | | | | | | | | | | | | | |
| Plasma+(A/changeove)+Autoclean+4way+PTC | P | | | | | | | | | | | | | | | | | | | | | | | | | | | | | | | | | | | | | | | | |
| Plasma+(A/changeove)+A/clean+4way+Low A+PTC | Q | | | | | | | | | | | | | | | | | | | | | | | | | | | | | | | | | | | | | | | | |
| Smart(Robot) Cleaning | R | | | | | | | | | | | | | | | | | | | | | | | | | | | | | | | | | | | | | | | | |
| Eco eye + Plasma + Allergy Filter + 4way | S | | | | | | | | | | | | | | | | | | | | | | | | | | | | | | | | | | | | | | | | |
| Plasma + Allergy Filter + 4way | U | | | | | | | | | | | | | | | | | | | | | | | | | | | | | | | | | | | | | | | | |
| Allergy Filter + 4way | V | | | | | | | | | | | | | | | | | | | | | | | | | | | | | | | | | | | | | | | | |
| Allergy Filter + 2way | W | | | | | | | | | | | | | | | | | | | | | | | | | | | | | | | | | | | | | | | | |
| Basic + Low Ambient | Y | | | | | | | | | | | | | | | | | | | | | | | | | | | | | | | | | | | | | | | | |
| Basic+(A/clean)+4way+Low A | Z | | | | | | | | | | | | | | | | | | | | | | | | | | | | | | | | | | | | | | | | |
| 10 | Serial No. | 1~9 | LG Model Development Serial No. | | | | | | | | | | | | | | | | | | | | | | | | | | | | | | | | | | | | | | |

Part 2 Functions & Controls

| | |
|---------------------------------------|----|
| 1. List of Controls & Functions | 9 |
| 2. Basic Mode Controls..... | 10 |
| 3. Special Mode Controls..... | 12 |
| 4. Utility Functions | 13 |

1. List of Functions & Controls

| Category | Function | Description | Remark |
|-----------------------|--------------------------|--|--------|
| Basic mode controls | Cooling Mode | Cooling operation | |
| | Heating Mode | Heating operation | |
| | Healthy Dehumidification | Dry operation | |
| | Auto Changeover | Cooling mode is automatically changed to heating mode and vice verse | |
| Special Mode controls | Jet Cool | Powerful cooling mode | |
| | Jet Heat | Powerful heating mode | |
| | Energy saving | Air volume & set temp. are automatically selected for saving energy in cooling mode | |
| Utility Functions | Forced operation | Operation without remote controller | |
| | Auto Clean | After cooling operation, this function makes the evaporator dry | |
| | Air volume control | Indoor Fan speed Control | |
| | Natural Air control | Air volume control Program | |
| | Auto Swing | Vertical Airflow Direction control | |
| | Sleep mode Auto control | Air volume & set temp. are automatically changed for comfortable sleep | |
| | Auto Restart Function | When power returns after a power failure, Unit restarts in the previous operating mode | |

NOTE: The Exploded View SVC Manual has the particular Function table for each model.

2. Basic Mode Controls

2.1 Cooling Mode

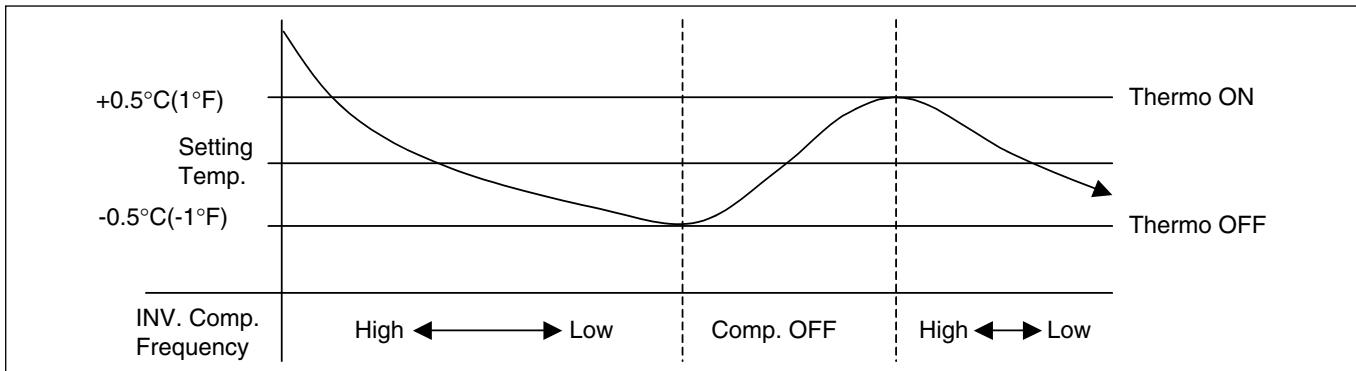

- Operating frequency of compressor depends on the load condition, like the difference between the room temp. and the set temp., frequency restrictions.
- If the compressor operates at some frequency, the operating frequency of compressor cannot be changed within 90 seconds. (not emergency conditions)
- Compressor turned off when
 - Intake air temperature reaches below 0.5°C(1°F) of the setting temperature for three minute continuously.
 - Intake air temperature reaches below 1.5°C(3°F) of the setting temperature
- Compressors 3 minute time delay.
 - After compressor off, the compressor can restart minimum 3 minute later.

2.2 Heating Mode

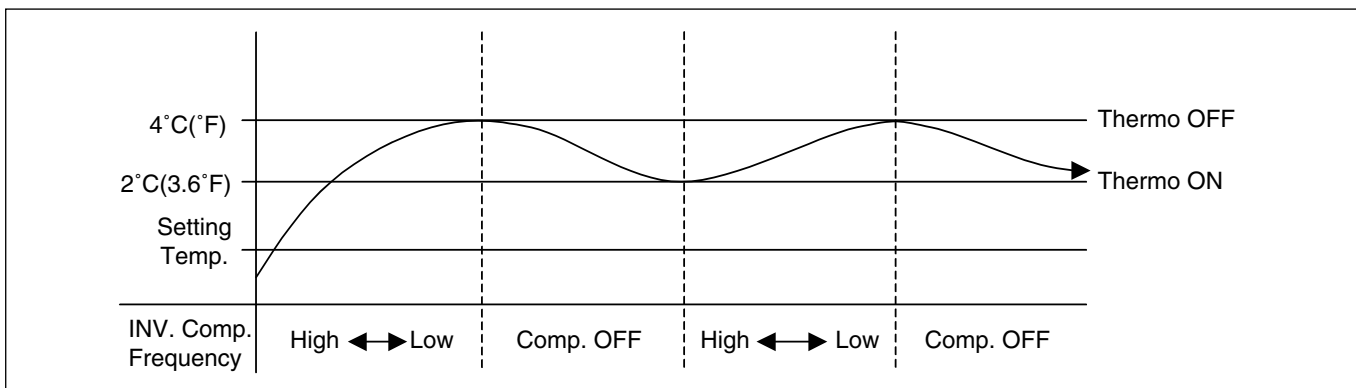

- Operating frequency of compressor depend on the load condition, The difference between the room temp. and set temp., frequency restrictions.
- If compressor operates at some frequency, the operating frequency of compressor cannot be changed within 90 seconds.
- Condition of compressor turned off
 - When intake air temperature reaches 4°C(°F) above the setting temperature.
- Condition of compressor turned on
 - When intake air temperature reaches below 2°C(3.6°F) of above the setting temperature.
- * Condition of indoor fan turned off
- While in defrost control, the indoor and outdoor fans are turned off.
- Compressor 3 minut delay
 - After compressor off, the compressor can restart minimum 3 minute later.

2.3 Healthy Dehumidification operation

- When the dehumidification operation is set by the remote controller, the intake air temperature is detected and the setting temp. is automatically set according to the intake air temperature.

| Intake air Temp. | Setting Temp. |
|--|---|
| $26^{\circ}\text{C}(78.8^{\circ}\text{F}) \leq \text{intake air temp.}$ | $25^{\circ}\text{C}(77^{\circ}\text{F})$ |
| $24^{\circ}\text{C}(75.2^{\circ}\text{F}) \leq \text{intake air temp.} < 26^{\circ}\text{C}(78.8^{\circ}\text{F})$ | intake air temp. $-1^{\circ}\text{C}(-2^{\circ}\text{F})$ |
| $22^{\circ}\text{C}(71.6^{\circ}\text{F}) \leq \text{intake air temp.} < 24^{\circ}\text{C}(75.2^{\circ}\text{F})$ | intake air temp. $-0.5^{\circ}\text{C}(-1^{\circ}\text{F})$ |
| $18^{\circ}\text{C}(64.4^{\circ}\text{F}) \leq \text{intake air temp.} < 22^{\circ}\text{C}(71.6^{\circ}\text{F})$ | intake air temp. |
| intake air temp. $< 18^{\circ}\text{C}(64.4^{\circ}\text{F})$ | $18^{\circ}\text{C}(64.4^{\circ}\text{F})$ |

- When intake air temp. is $1^{\circ}\text{C}(2^{\circ}\text{F})$ above the setting temp., condition of compressor is same as in cooling mode operation.
- When intake air temperature reaches $1^{\circ}\text{C}(2^{\circ}\text{F})$ below the setting temp., compressor operates in step1~step3 and the indoor fan speed again operates at low speed or comes to a stop.

2.4 Auto changeover operation

- The air conditioner changes the operation mode automatically to keep indoor temperature steady.
- When room temperature vary over $\pm 2^{\circ}\text{C}(\pm 4^{\circ}\text{F})$ with respect to setting temperature, air conditioner keeps the room temperature in $\pm 2^{\circ}\text{C}(\pm 4^{\circ}\text{F})$ with respect to setting temperature by changing the mode from cooling to heating and vice versa.

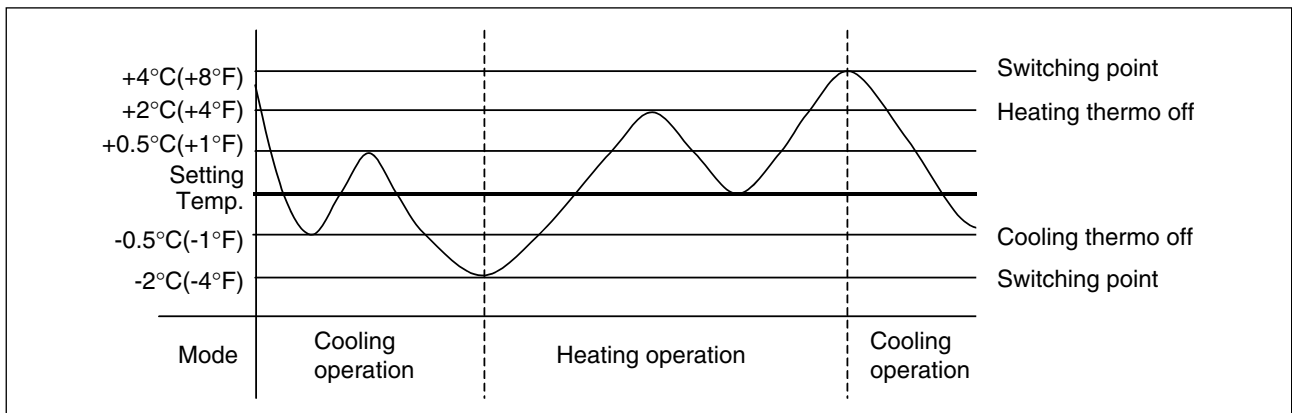

3. Special Mode Controls

3.1 Jet Cool operation

- In the heating mode or Auto Changeover operation, the Jet cool function does not work.
When it is input while in other mode of operation (cooling, dehumidification, Air purification, Air circulation), the Jet cool operation takes place.
- In the Jet cool mode, the indoor fan is operated at super-high speed for 30 min. at cooling mode operation.
- In the Jet cool mode, the room temperature is maintained at a setting temperature of 18°C(64.4°F).
- When the sleep timer mode is input during the Jet cool operation, the Jet cool mode has the priority.
- When the Jet cool button is pressed, the horizontal vane of the unit is reset to those of the initial cooling mode and then operate so that the air outflow could reach further.

3.2 Jet Heat operation

- While in cooling mode or Auto Changeover operation, the Jet Heat function does not work.
When it is input while in the Heating mode operation (dehumidification), the Jet Heat mode operation takes place
- In the Jet Heat mode, the indoor fan operated at super-high speed for 60 min. at Heating mode operation.
- In the Jet Heat mode, the room temperature is maintained at a temperature of 30°C(86°F).
- When the sleep timer mode is input during the Jet Heat mode operation, the Jet Heat mode has the priority.
- When the Jet Heat button is pressed, the horizontal vane of the unit is the unit reset to those of the initial Jet heating mode and then operates so that the air outflow could reach under flow.

3.3 Energy saving operation in cooling mode

- During cooling and dehumidification mode of operation, the Energy saving button can be input.
- In this operation, before we feel cold the set temperature and air volume is set automatically to save energy.

4. Utility Functions

4.1 Forced operation

- To operate the appliance manually in case when the remote control is lost, the forced operation selection switch is on the main unit of the appliance, and operate the appliance in the standard conditions.
- The operating condition is set according to the outdoor temp. and intake air temperature as follows.

| Indoor temp. | Operating Mode | Setting temp. | Setting speed of indoor fan |
|----------------------|--------------------------|---------------|-----------------------------|
| over 24°C(75.2°F) | Cooling | 22°C(71.6°F) | High speed |
| 21~24°C(69.8~75.2°F) | Healthy Dehumidification | 23°C(73.4°F) | |
| below 21°C(69.8°F) | Heating | 24°C(75.2°F) | |

- Operating procedures when the remote control can't be used is as follows :
 - The operation will be started if the ON/OFF button is pressed.
 - If you want to stop operation, re-press the button.
 - The ON/OFF switch is on the display PCB or side of indoor unit

4.2 Auto cleaning operation

- Function used to perform Self Cleaning to prevent the Unit from Fungus and bad odor.
- Used after the Cooling Operation before turning the unit off, clean the Evaporator and keep it dry for the next operation.
- The function is easy to operate as it is accessed through the Remote controller.

| | ON | OFF |
|------------|---------------|---------------|
| | Cooling CYCLE | Fan |
| Comp. | ON | 30 Min OFF |
| Indoor Fan | Setting Step | Super Low |

4.3 Air volume control

- Indoor fan motor control have 6 steps or 8 steps.
- Air volume is controlled "SH", "H", "MH", "M", "ML", "L" by the remote controller.
- "SL" step is selected in "Sleep Mode" operation.

| Step | Description |
|------|--------------|
| SL | Super Low |
| L | Low |
| ML | Medium-Low |
| M | Medium |
| MH | Medium-High |
| H | High |
| SH | Super High |
| Auto | Natural Wind |

4.4 Natural Air Control(Natural Wind)

- When the Auto Step is selected and then operated, the high, medium, or low speed of the airflow mode is operated for 2~15 sec. randomly by the Chaos Simulation.

4.5 Auto Swing

- By the Auto swing key input, the horizontal vane automatically operates with the Auto swing or it is fixed to the desired direction.

4.6 Sleep mode Auto control

- When the set sleep time is reached set time of [1,2,3,4,5,6,7hour] input by the remote control during the operation, the operation of the appliance stops.
- When the appliance is on pause, the sleep timer mode cannot be input.

4.6.1 Sleep timer operation for cooling cycle

- While in cooling mode, 30 min. after the start of the sleep timer, the setting temperature increases by 1°C(2°F). After another 30 minutes lapse, it increases again by 1°C(2°F).

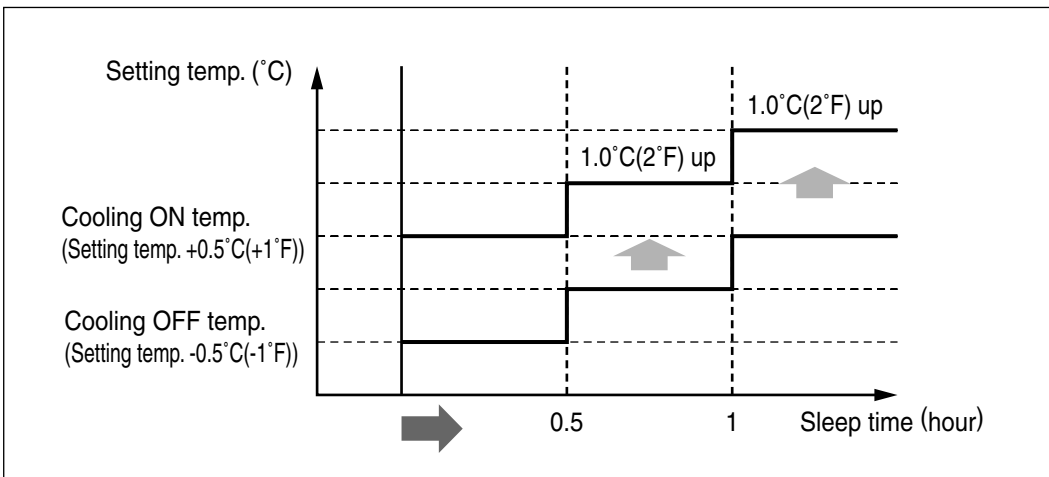

NOTE: Some Models are different by swing width and swing pattern.

4.6.2 Sleep timer operation for heating cycle

- While in heating mode, 60 min. after the start of the sleep timer, the setting temperature decreases by 1°C(2°F). After another 60minutes lapse, it decreases again by 1°C(2°F).

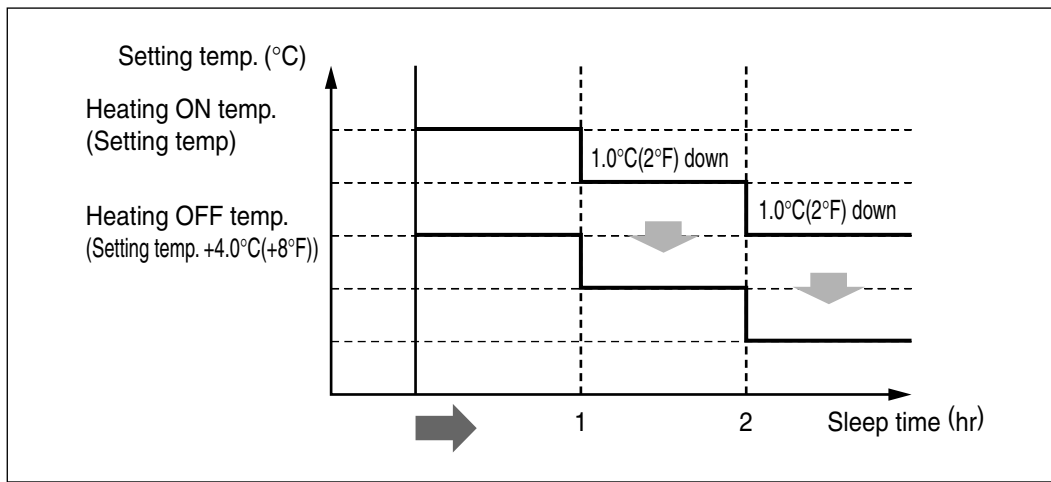

4.7 Auto restart

- When the power comes back after a sudden power failure during operation, the mode before the power failure is kept on the memory of the appliance and it automatically operates in the saved mode on the memory.
- Operation mode that is kept on the memory
 - State of operation ON/OFF
 - Operation mode/setting temp./selected airflow speed
 - Sleep timer mode/remaining time of sleep timer
 - Auto Swing

Part 3 Test Run

| | |
|-------------------------------|----|
| 1. Check before Test Run..... | 17 |
| 2. Test Run Flow chart | 18 |
| 3. Test Run Detail..... | 19 |

1. Check before Test Run

| | |
|----------|--|
| 1 | Check to see whether there is any refrigerant leakage, and check whether the power or transmission cable is connected properly. |
| 2 | Check whether the liquid pipe and gas pipe valves are fully opened. NOTE: Be sure to tighten caps. |
| 3 | Confirm that 500 V megger shows 2.0 MΩ or more between power supply terminal block and ground. Do not operate in the case of 2.0 MΩ or less. NOTE: Never carry out mega ohm check over terminal control board. Otherwise the control board may break. Immediately after mounting the unit or after leaving it turned off for an extended length of time, the resistance of the insulation between the power supply terminal board and the ground may decrease to approx. 2.0 MΩ as a result of refrigerant accumulation in the internal compressor. If the insulation resistance is less than 2.0 MΩ, turn on the main power supply. |

2. Test Run Flow chart

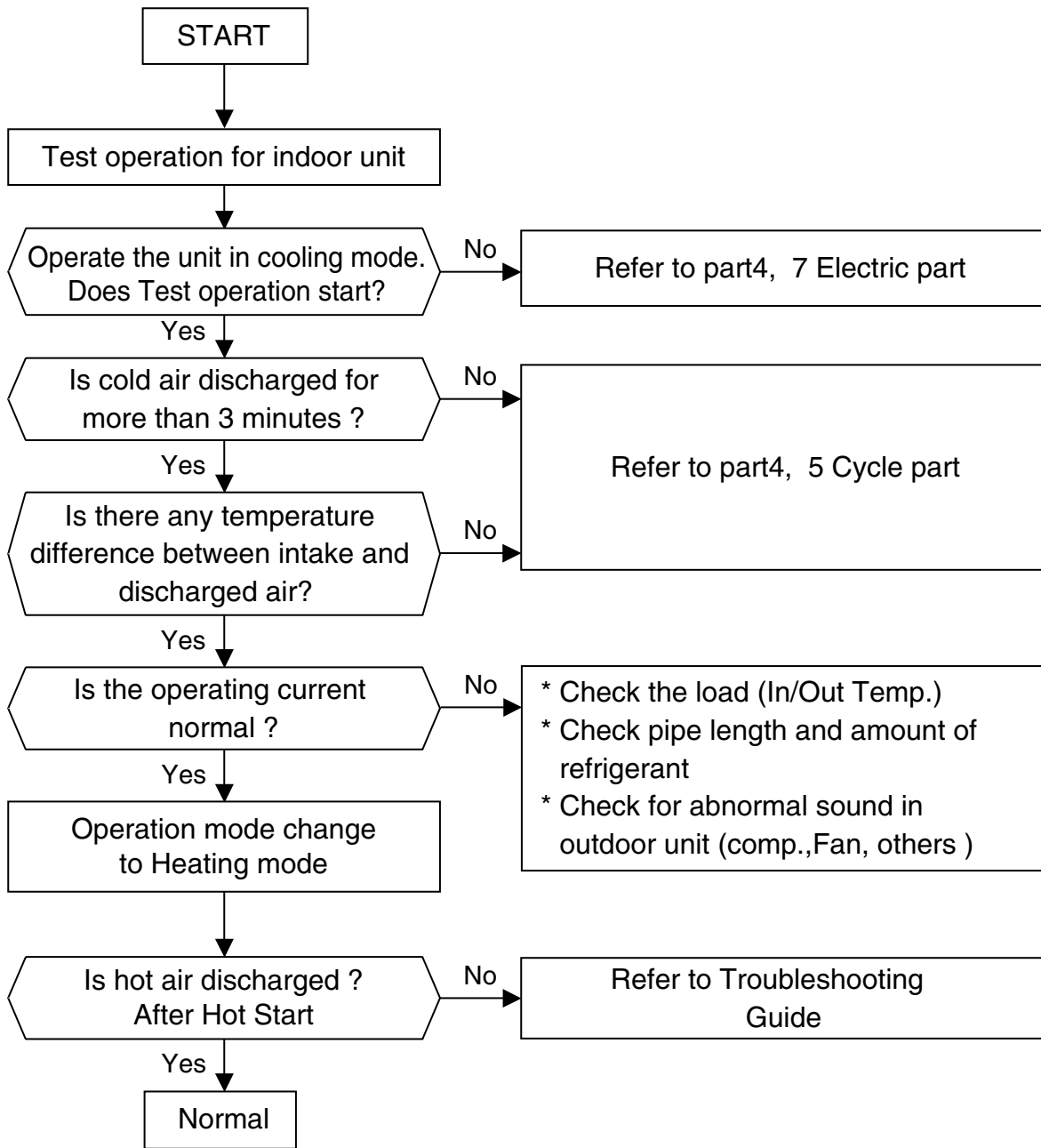

NOTE: When outdoor temperature is low, the unit is operated to Heating mode

3. Test Run Detail

1. Check that all tubing and wiring have been properly connected.
2. Check that the gas and liquid side service valves are fully open.

Settlement of outdoor unit

- Anchor the outdoor unit with a bolt and nut(ø10mm) tightly and horizontally on a concrete or rigid mount.
- When installing on the wall, roof or rooftop, anchor the mounting base securely with a nail or wire assuming the influence of wind and earthquake.
- In the case when the vibration of the unit is conveyed to the hose, secure the unit with an anti-vibration bushing.

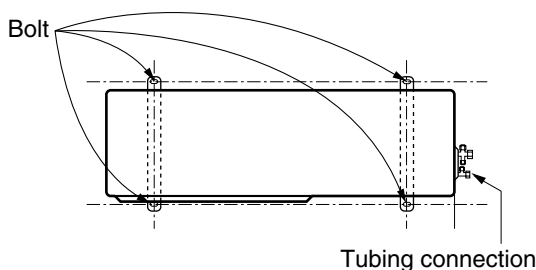

Evaluation of the performance

Operate unit for 15~20 minutes, then check the system refrigerant charge:

1. Measure the pressure of the gas side service valve.
2. Measure the temperature of the intake and discharge air.
3. Ensure the difference between the intake temperature and the discharge is more than 8°C(46°F) (Cooling) or (Heating).

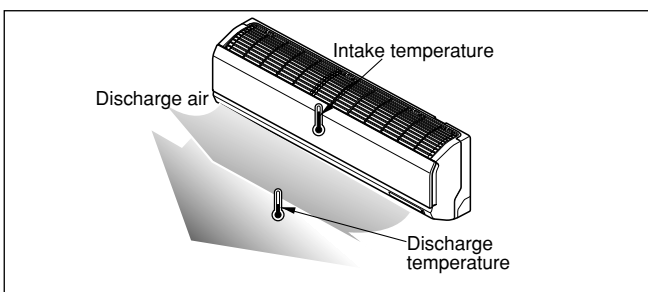

4. For reference; the gas side pressure of optimum condition is as below.(Cooling)

| Refrigerant | Outside ambient TEMP. | The pressure of the gas side service valve. |
|-------------|-----------------------|---|
| R22 | 35°C (95°F) | 4~5kg/cm ² G(56.8~71.0 P.S.I.G.) |
| R410A | 35°C (95°F) | 8.5~9.5kg/cm ² G(120~135 P.S.I.G.) |

NOTE: If the actual pressure is higher than shown, the system is most likely over-charged, and charge should be removed.
If the actual pressure are lower than shown, the system is most likely undercharged, and charge should be added.

The air conditioner is now ready for use.

PUMP DOWN

This is performed when the unit is to be relocated or the refrigerant circuit is serviced.

Pump Down means collecting all refrigerant in the outdoor unit without loss in refrigerant gas.

CAUTION:

Be sure to perform Pump Down procedure with the unit in cooling mode.

Pump Down Procedure

1. Connect a low-pressure gauge manifold hose to the charge port on the gas side service valve.
2. Open the gas side service valve halfway and purge the air from the manifold hose using the refrigerant gas.
3. Close the liquid side service valve(all the way in).
4. Turn on the unit's operating switch and start the cooling operation.
5. When the low-pressure gauge reading becomes 1 to 0.5kg/cm² G(14.2 to 7.1 P.S.I.G.), fully close the gas side valve stem and then quickly turn off the unit. At that time, Pump Down has been completed and all refrigerant gas will have been collected in the outdoor unit.
5. Check operating current.
6. Change operation mode and check.

Part 4 Trouble Shooting

| | |
|--|----|
| 1. 2-Way, 3-Way Valve | 21 |
| 2. Pumping Down | 22 |
| 3. Evacuation (All amount of refrigerant leaked) | 23 |
| 4. Gas Charging (After Evacuation) | 24 |
| 5. Cycle Troubleshooting Guide..... | 25 |
| 6. Electronic Parts Troubleshooting Guide | 26 |
| 7. Self-diagnosis Function..... | 30 |

1. 2-Way, 3-Way Valve

| | | 2-way Valve (Liquid Side) | 3-way Valve (Gas Side) | |
|-----------|-----------------------------|---------------------------|--------------------------|-------------------------------------|
| | | | | |
| Works | | Shaft position | Shaft position | Service port |
| Shipping | | Closed (with valve cap) | Closed (with valve cap) | Closed (with cap) |
| 1. | Air purging (Installation) | Open (counter-clockwise) | Closed (clockwise) | Open (push-pin or with vacuum pump) |
| Operation | | Open (with valve cap) | Open (with valve cap) | Closed (with cap) |
| 2. | Pumping down (Transferring) | Closed (clockwise) | Open (counter-clockwise) | Open (connected manifold gauge) |
| 3. | Evacuation (Servicing) | Open | Open | Open (with charging cylinder) |
| 4. | Gas charging (Servicing) | Open | Open | Open (with charging cylinder) |
| 5. | Pressure check (Servicing) | Open | Open | Open (with charging cylinder) |
| 6. | Gas releasing (Servicing) | Open | Open | Open (with charging cylinder) |

2. Pumping Down

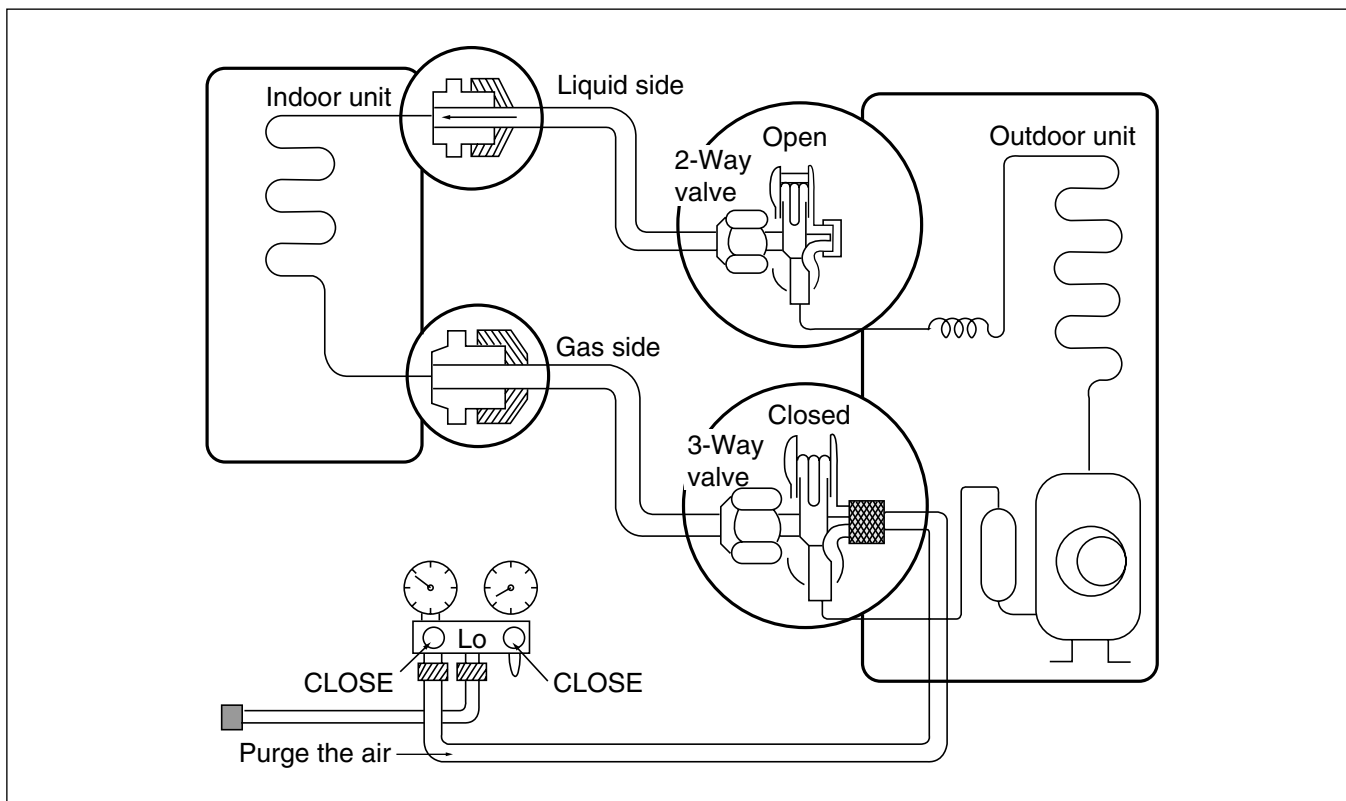

• Procedure

- (1) **Confirm that both the 2-way and 3-way valves are set to the open position.**
 - Remove the valve stem caps and confirm that the valve stems are in the raised position.
 - Be sure to use a hexagonal wrench to operate the valve stems.
- (2) **Operate the unit for 10 to 15 minutes.**
- (3) **Stop operation and wait for 3 minutes, then connect the charge set to the service port of the 3-way valve.**
 - Connect the charge hose with the push pin to the service port.
- (4) **Air purging of the charge hose.**
 - Open the low-pressure valve on the charge set slightly to air purge from the charge hose.
- (5) **Set the 2-way valve to the closed position.**
- (6) **Operate the air conditioner at the cooling cycle and stop it when the gauge indicates $1\text{kg/cm}^2\cdot\text{g}$.**
- (7) **Immediately set the 3-way valve to the closed position.**
 - Do this quickly so that the gauge ends up indicating 3 to $5\text{kg/cm}^2\cdot\text{g}$.
- (8) **Disconnect the charge set, and mount the 2-way and 3-way valve's stem nuts and the service port nut.**
 - Use torque wrench to tighten the service port nut to a torque of $1.8\text{ kg}\cdot\text{m}$.
 - Be sure to check for gas leakage.

3. Evacuation (All amount of refrigerant leaked)

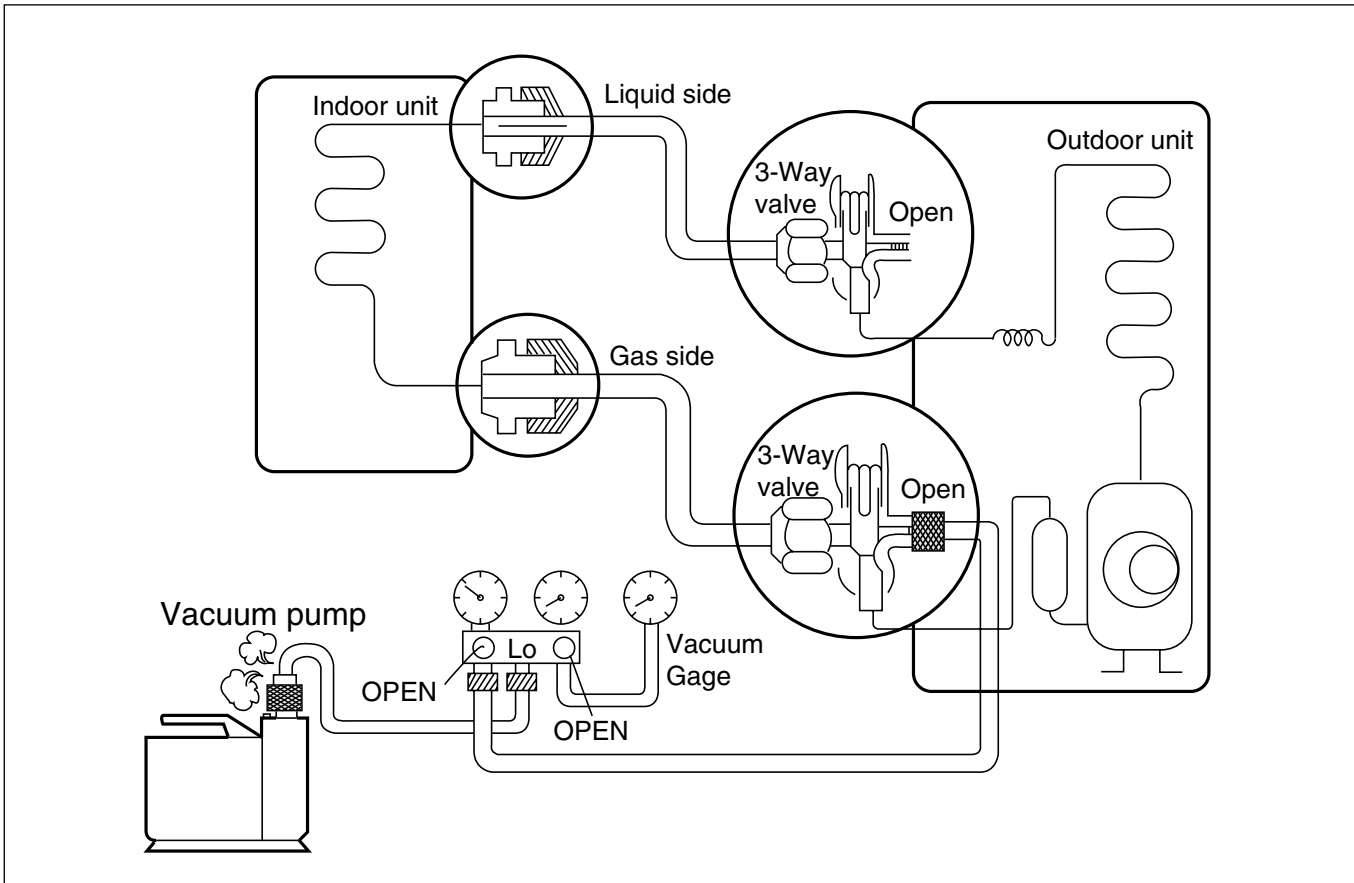

• Procedure

- (1) Connect the vacuum pump to the center hose of charge set center hose
- (2) Evacuation for approximately one hour.
 - Confirm that the gauge needle has moved toward 0.8 Torr.
- (3) Close the valve (Lo side) on the charge set, turn off the vacuum pump, and confirm that the gauge needle does not move (approximately 5 minutes after turning off the vacuum pump).
- (4) Disconnect the charge hose from the vacuum pump.
 - Vacuum pump oil.
 - If the vacuum pump oil becomes dirty or depleted, replenish as needed.

4. Gas Charging (After Evacuation)

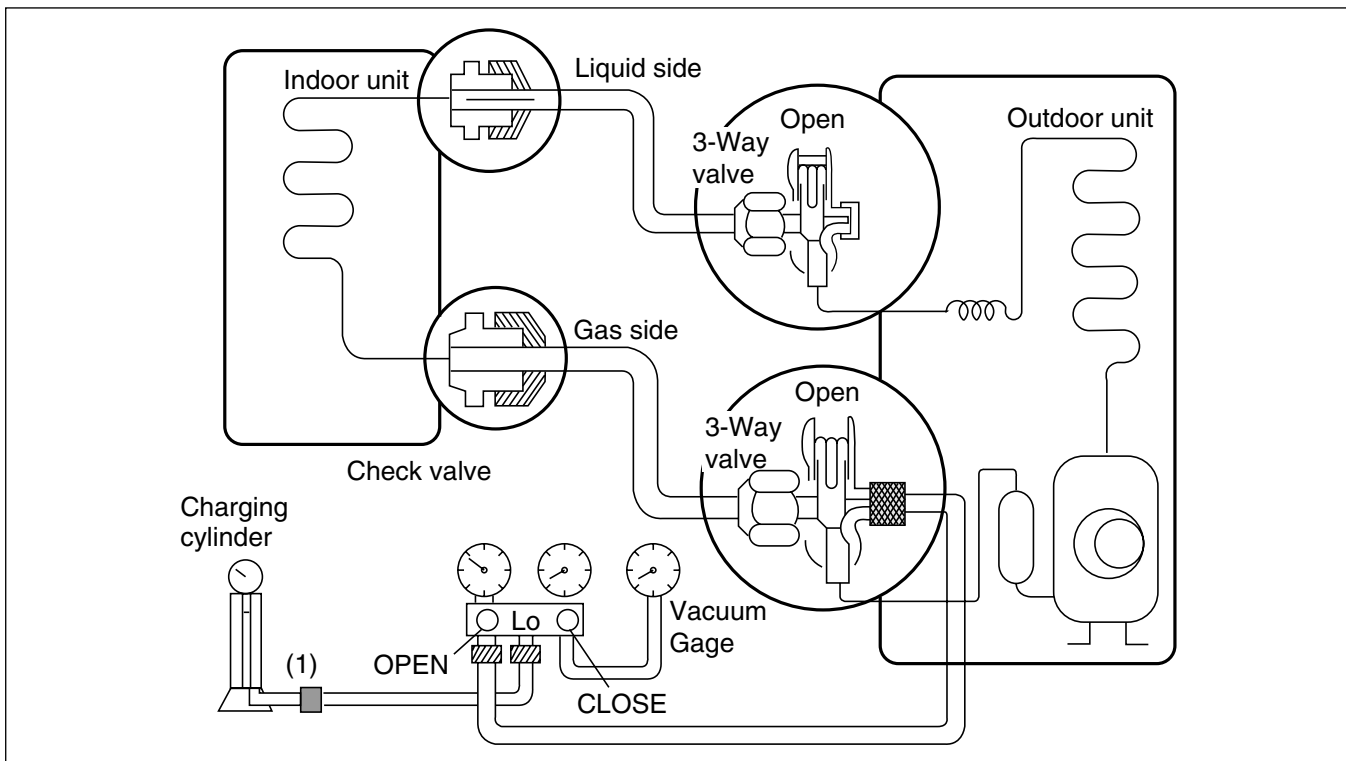

• Procedure

(1) Connect the charge hose to the charging cylinder.

- Connect the charge hose which you disconnected from the vacuum pump to the valve at the bottom of the cylinder.
- If you are using a gas cylinder, also use a scale and reverse the cylinder so that the system can be charged with liquid.

(2) Purge the air from the charge hose.

- Open the valve at the bottom of the cylinder and press the check valve on the charge set to purge the air. (Be careful of the liquid refrigerant). The procedure is the same if using a gas cylinder.

(3) Open the valve (Lo side on the charge set and charge the system with liquid refrigerant.

- If the system can not be charged with the specified amount of refrigerant, it can be charged with a little at a time (approximately 150g each time) while operating the air conditioner in the cooling cycle; however, one time is not sufficient, wait approximately 1 minute and then repeat the procedure (pumping down-pin).

This is different from previous procedures.

Because you are charging with liquid refrigerant from the gas side, absolutely do not attempt to charge with larger amounts of liquid refrigerant while operating the air conditioner.

(4) Immediately disconnect the charge hose from the 3-way valve's service port.

- Stopping partway will allow the gas to be discharged.
- If the system has been charged with liquid refrigerant while operating the air conditioner turn off the air conditioner before disconnecting the hose.

(5) Mount the valve stem nuts and the service port nut.

- Use torque wrench to tighten the service port nut to a torque of 1.8 kg.m.
- Be sure to check for gas leakage.

5. Cycle Troubleshooting Guide

Trouble analysis

1. Check temperature difference between intake and discharge air, and operating current.

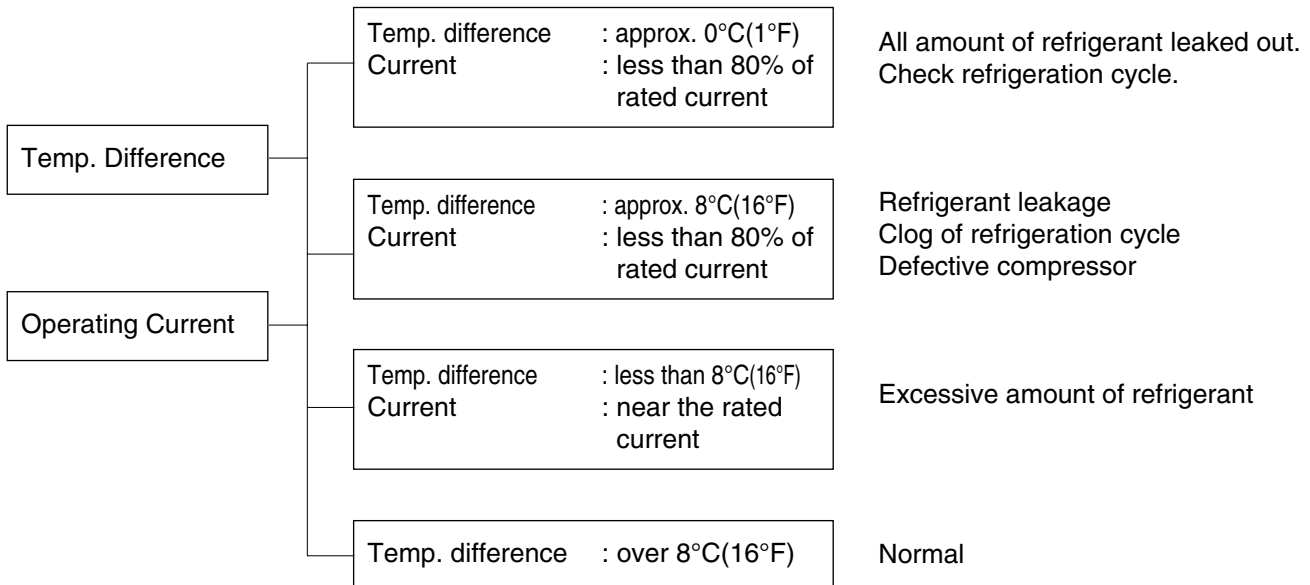

NOTICE

Temperature difference between intake and discharge air depends on room air humidity. When the room air humidity is relatively higher, temperature difference is smaller. When the room air humidity is relatively lower temperature difference is larger.

6. Electronic Parts Troubleshooting Guide

Trouble 1

The Product doesn't operate at all. (9~30kBTu/h Model)

Turn off the main power and wait until LED on outdoor PCB is off.



Turn on the main power again.



Does "Beeping" sound is made from the indoor unit?
Does "Lighting" LED is mounted on the outdoor PCB?



Check the voltage of power(AC 208~230V, 60Hz).

- The voltage of main power.
- The voltage applied to the unit.
- The connecting method of Indoor/Outdoor connecting cable (each color)
- The P.W.B. Ass'y (Fuse,Noise Filter, Power Module(SMPS), IC01D,IC04D)

- Primarily, the operating condition of Micom is O.K.



- Check CN-DISP1

| The operation check of the P.C.B. Ass'y | | |
|--|----------------|--------------------|
| Procedure | Specification | Remedy |
| 1) The input voltage of Power Module(SMPS) | : DC 220V~390V | Replace the P.C.B. |
| 2) The output voltage of Power Module (SMPS) | : 15V ±10% | |
| 3) IC01D(LD1085), IC04D(7805) | : DC 5V | |

Trouble 2

Product doesn't operate with the remote controller.

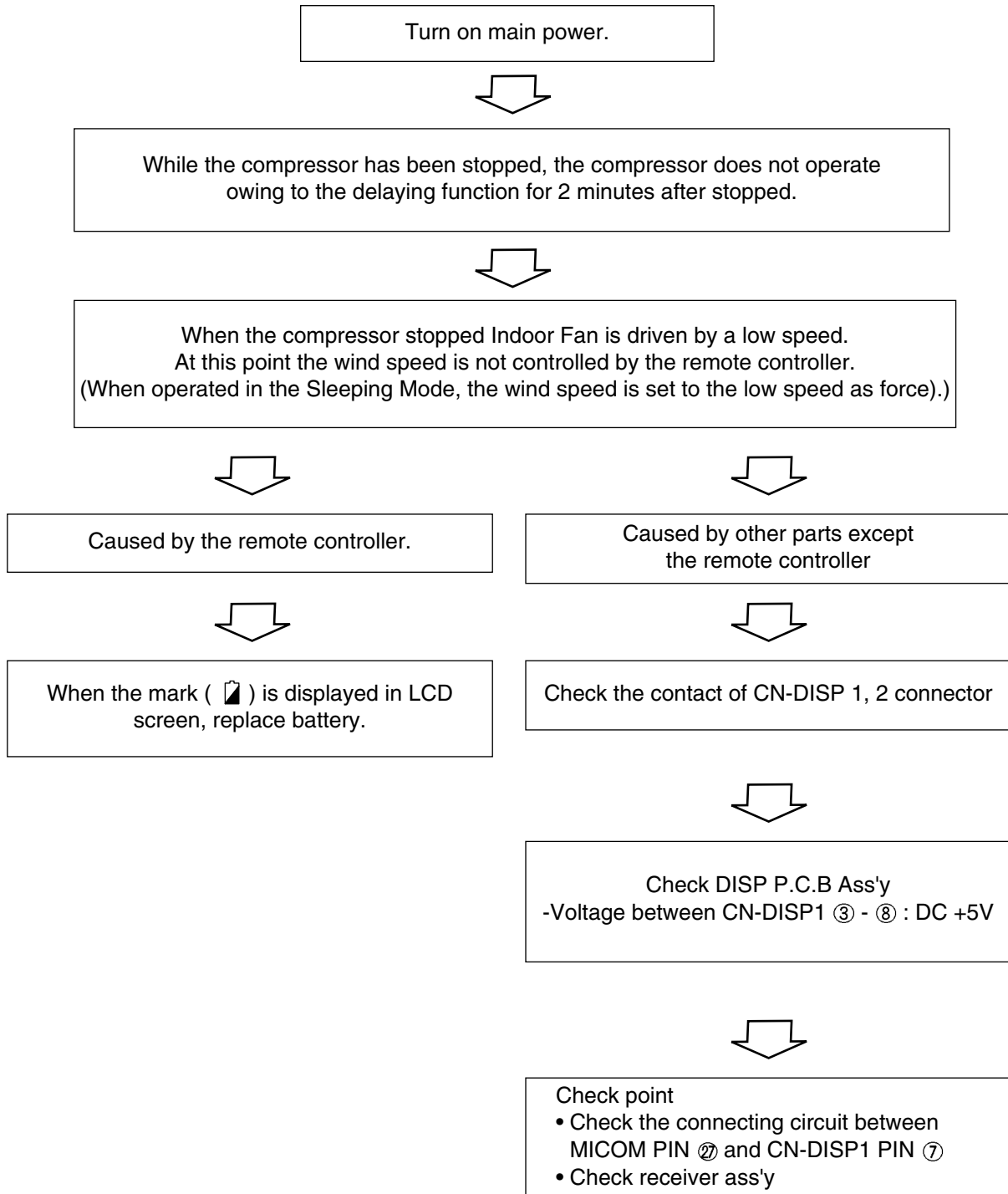

Trouble 3

The Compressor/Outdoor Fan don't operate

Turn on the main power.



Operate Cooling Mode by setting the disired temperature of the remote controller is less than one of the Indoor temperature by 1°C at least.



When in air circulation mode, compressor/outdoor fan is stopped.



Check the sensor for Indoor temperature is attached as close as to be effected by the temperature of Heat Exchange (EVA.)



When displaying Error code, refer to the trouble shooting guide.



Check the main power source.(AC 208V~230V)
Check the trouble shooting guide error code 21,26.
Check that CN_FAN(A,B) supplied voltage to outdoor PCB is about AC 208V~230V.



Turn off main power.



Check the electrical wiring diagram of Outdoor side.
Check the open or short of connecting wires between Indoor and Outdoor.

Trouble 4

When indoor Fan does not operate

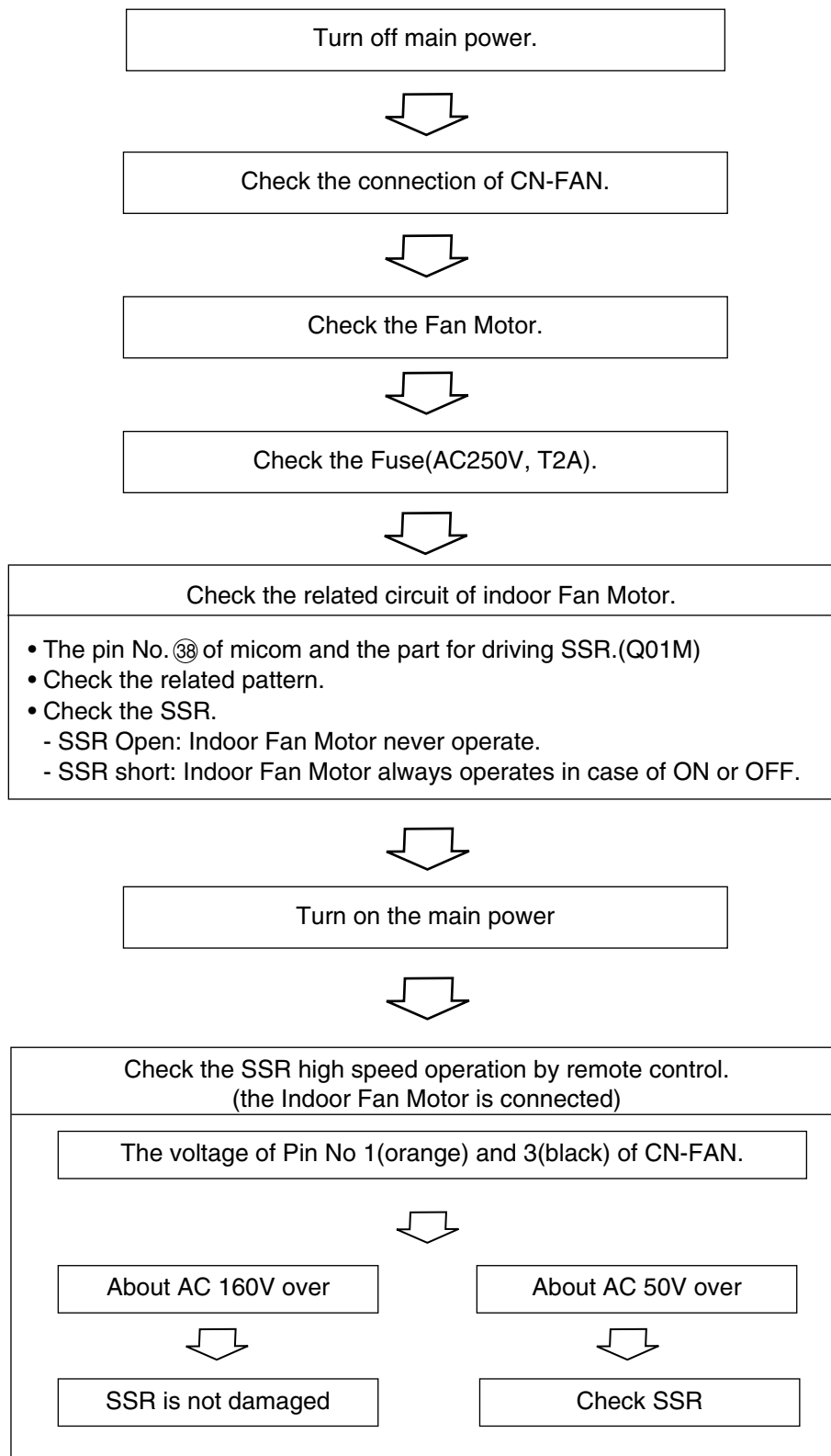

7. Self-diagnosis Function

■ Error Indicator

- The function is to self-diagnosis airconditioner and express the troubles identifiably if there is any trouble.
- If more than two troubles occur simultaneously, primarily the highest trouble fo error code is expressed.
- After error occurrence, if error is released, error LED is also released simultaneously.
- To operate again on the occurrence of error code, be sure to turn off the power and then turn on.
- Having or not of error code is different from Model.

■ Indoor Unit Error

1. SB, SC, SH, S4, S5 Chassis

| Error Code | Description | Error Indication | | | |
|------------|---|------------------|--------|--------------|--------------|
| | | Indoor Unit | | Outdoor Unit | |
| | | LED1 | LED2 | LED1 (Red) | LED2 (Green) |
| 1 | Indoor Sensor(Air) open/short | 1 Time | - | - | - |
| 2 | Indoor Sensor(Entry Pipe) open/short | 2 Times | - | - | - |
| 5 | Communication Failure(Indoor Unit ↔ Outdoor Unit) | 5 Times | - | - | - |
| 6 | Indoor Sensor(Exit Pipe) open/short | 6 Times | - | - | - |
| 9 | EEPROM ERROR(Indoor Unit) | 9 Times | - | - | - |
| 10 | Indoor Unit Fan Lock(Operation Failure) | - | 1 Time | - | - |
| 12 | Indoor Sensor(Middle Pipe) open/short | 2 Times | 1 Time | - | - |

1) SB, SC, Chassis

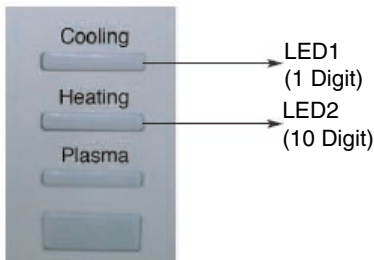

2) S4, S5 Chassis (4 LED Model)

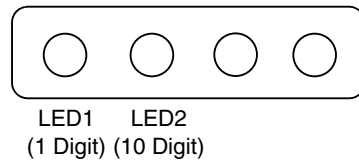

3) SH Chassis



2. SE Mirror, S8, SD Chassis

Ex) Error Code 5 (Communication Failure)



Outdoor Unit Error

1) 2 LED Type



LED1
(Green, 1 Digit)
LED2
(Red, 10 Digit)

2) 1 LED Type

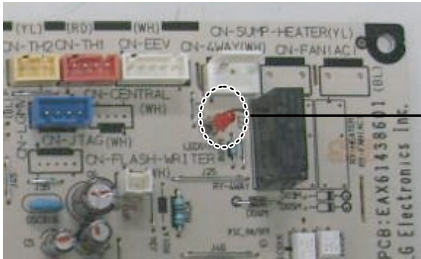

Red LED

Ex) Error Code 21 (DC Peak)

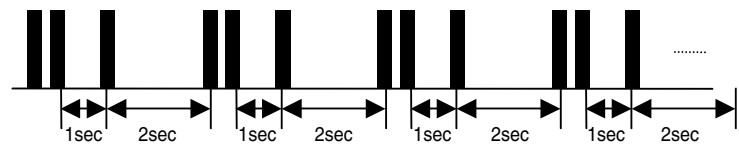

| Error Code | Description | Error Indication | | | |
|------------|---|------------------|---------|--------------|---------|
| | | Indoor Unit | | Outdoor Unit | |
| | | LED1 | LED2 | LED1 | LED2 |
| 21 | DC Peak (IPM Fault) | 2 Times | 1 Time | 2 Times | 1 Time |
| 22 | CT 2(Max CT) | 2 Times | 2 Times | 2 Times | 2 Times |
| 23 | DC Link Low Volt | 2 Times | 3 Times | 2 Times | 3 Times |
| 25 | Low wire volt/ high wire volt | 2 Times | 5 Times | 2 Times | 5 Times |
| 26 | DC Comp Position Error | 2 Times | 6 Times | 2 Times | 6 Times |
| 27 | PSC Fault Error | 2 Times | 7 Times | 2 Times | 7 Times |
| 28 | DC Link High Volt | 2 Times | 8 Times | 2 Times | 8 Times |
| 29 | Inverter Compressor over-current | 2 Times | 9 Times | 2 Times | 9 Times |
| 31 | CT error (low current) | 3 Times | 1 Time | 3 Times | 1 Time |
| 32 | D-Pipe High (INV) | 3 Times | 2 Times | 3 Times | 2 Times |
| 40 | CT Sensor (Open / Short) | 4 Times | - | 4 Times | - |
| 41 | INV. D-Pipe Th Error (Open / Short) | 4 Times | 1 Time | 4 Times | 1 Time |
| 44 | Outdoor Air Th Error (Open / Short) | 4 Times | 4 Times | 4 Times | 4 Times |
| 45 | Cond. Middle Pipe Error (Open / Short) | 4 Times | 5 Times | 4 Times | 5 Times |
| 48 | Cond. Out Pipe Error (Open / Short) | 4 Times | 8 Times | 4 Times | 8 Times |
| 53 | Communication Failure(Outdoor Unit ↔ Indoor Unit) | 5 Times | 3 Times | 5 Times | 3 Times |
| 60 | EEPROM Check Sum Error | 6 Times | - | 6 Times | - |
| 61 | Cond. Pipe High | 6 Times | 1 Time | 6 Times | 1 Time |
| 62 | Heatsink High | 6 Times | 2 Times | 6 Times | 2 Times |
| 63 | Cond. Pipe Low | 6 Times | 3 Times | 6 Times | 3 Times |
| 65 | Heatsink Th Error (Open/Short) | 6 Times | 5 Times | 6 Times | 5 Times |

■ Troubleshooting Guide (Indoor Unit)

| Inspection Number | Description of Inspection | Cause of Error | Check Point |
|-------------------|---------------------------------------|-------------------|---|
| CH01 | Indoor Temperature Sensor | Sensor short/open | Check Sensor connection status and Check Sensor Resistance |
| CH02 | Indoor pipe entry temperature sensor | Sensor short/open | Check Sensor connection status and Check Sensor Resistance |
| CH06 | Indoor pipe exit temperature sensor | Sensor short/open | Check Sensor connection status and Check Sensor Resistance |
| CH12 | Indoor pipe middle temperature sensor | Sensor short/open | Check Sensor connection status and Check Sensor Resistance |

1. Check if the temperature connection part is securely connected.
2. After disconnecting from Temperature Sensor PCB Assembly, measure each sensor's resistance.

• Location of the sensor

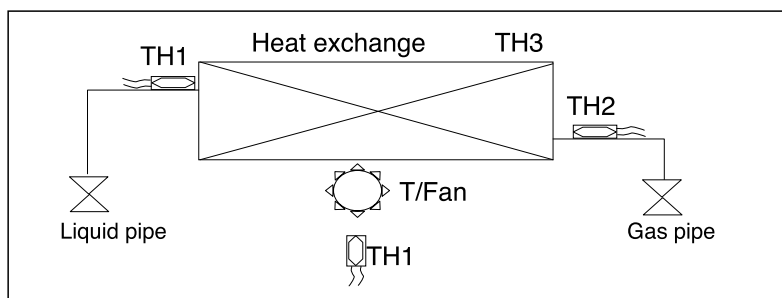

• Air Conditioner Operation Standard

| Symbol | Color of the Connector | Title | Resistance | Remark |
|--------|------------------------|----------------------------------|---------------|------------|
| TH1 | White (CN-TH1) | Indoor Temperature Sensor | 10 K Ω | 25°C Basis |
| | | Pipe entrance Temperature Sensor | 5K Ω | |
| TH2 | Red (CN-TH2) | Middle Pipe Temperature Sensor | 5K Ω | |
| TH3 | White (CN-TH3) | Pipe Exit Temperature Sensor | 5K Ω | |

3. If the measurement indicates infinite or 0 Ω please replace temperature sensor.
4. If the measurement is normal, then please check main indoor PCB and replace.

Method of Measurement

1. Disconnect Temperature Sensor connector from the board.
2. Place the range of the tester at Ω .
3. Measure the connector resistance.

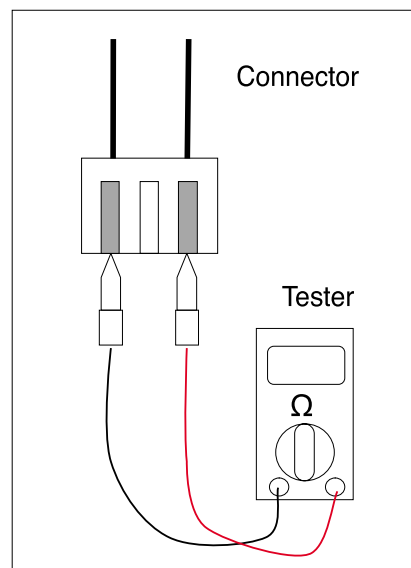

| Inspection Number | Description of Inspection | Cause of Error | Check Point |
|-------------------|--|---|---|
| CH05 | Poor Communication (Indoor <-> Outdoor unit) | The communication between indoor <-> outdoor unit is stopped for more than 3 minutes. | <ul style="list-style-type: none"> • AC 220V power input(indoor, outdoor unit) • Disconnection of the transmission connection • Poor connection of connecting wires • Communication line short in GND • No power to outdoor unit PCB(burned) / faulty communication circuit • faulty outdoor unit PCB communication circuit • GND 1, 2 not connected to the main power GND |

1. Check input power AC 220V (indoor, outdoor unit)
2. Check proper connection of the communication line => check the status of the connection wire fault and connector connections.
3. Check the resistance between the communication line and GND (normal : 2kΩ or more)
4. Check if the communication connections are properly connected.
5. Check indoor unit GND, outdoor unit GND, and main GND connections.
6. If the length of the communication line exceeds 50M, separate the communication lines.
7. Check for the products or power lines near the communication line that may cause noise.

| Inspection Number | Description of Inspection | Cause of Error | Check Point |
|-------------------|---------------------------|-------------------------------|---|
| CH09 | CN-OPTION PCB | Poor connection of OPTION PCB | Check the connection status of the OPTION PCB |

1. Check if the OPTION PCB is properly connected.

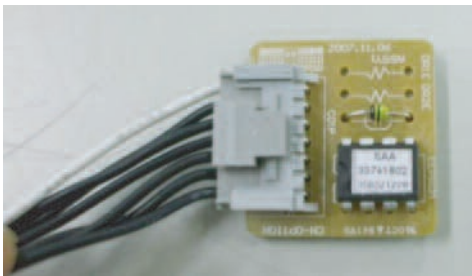

| Inspection Number | Description of Inspection | Cause of Error | Check Point |
|-------------------|---|---|--|
| CH10 | Indoor Fan Locking (faulty Motor operation) | If the Fan motor does not operate after 1 minute of initial operation | <ul style="list-style-type: none"> • Structural locking of Fan • Poor connection of the motor connector • Faulty motor • Faulty indoor unit PCB Assembly |

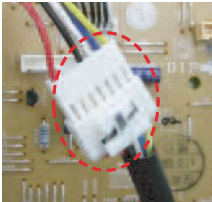
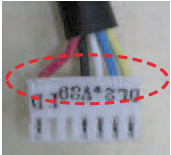
| | Type of Fault (check procedure) | Cause of Error | Verification | Remedies |
|---------------------------|--|---|---|--|
| Inspection Number CH10 | 1. Indoor Fan structurally Locking ↓ | • Fan is locked by the interference of other structures | • Turn the fan by hand and checking locking materials | • Release lock by reassembling, etc |
| | 2. Poor connection of motor connector ↓ | 1) motor connector displaced  | • Verify with eyes | • Repair |
| | 3. Faulty motor ↓ | 2) Housing terminal displaced  | • Verify with eyes | • Repair or replace motor |
| | 4. Faulty indoor unit PCB | 3) Wire disconnection or pressed • Motor inner PCB etc. burned | • Verify with eyes | • Replace motor • Replace indoor unit PCB |

■ Trouble Shooting Guide [Outdoor Unit (2 LED Type)]

1) CH21: DC Peak Error

| Inspection Number | Error Detection | Cause of Error | Check Point |
|-------------------|----------------------------------|---|--|
| CH21 | High current into the compressor | <ul style="list-style-type: none"> Compressor blocked Disconnection/short-circuit inside compressor Over load operation (Outdoor fan constraint, screened, blocked) Burned parts inside PCB | <ul style="list-style-type: none"> Check compressor constraint Check compressor wire open/short Check compressor insulation damage Check outdoor fan constraint / screened / flow structure Check if IPM burned |

warning Before checking PCB or each outdoor electric parts, wait for 3 minutes after the power is off. When measuring at standby state of power supply, after checking the measurement mode of the meter, be careful of the short-circuits with other parts.

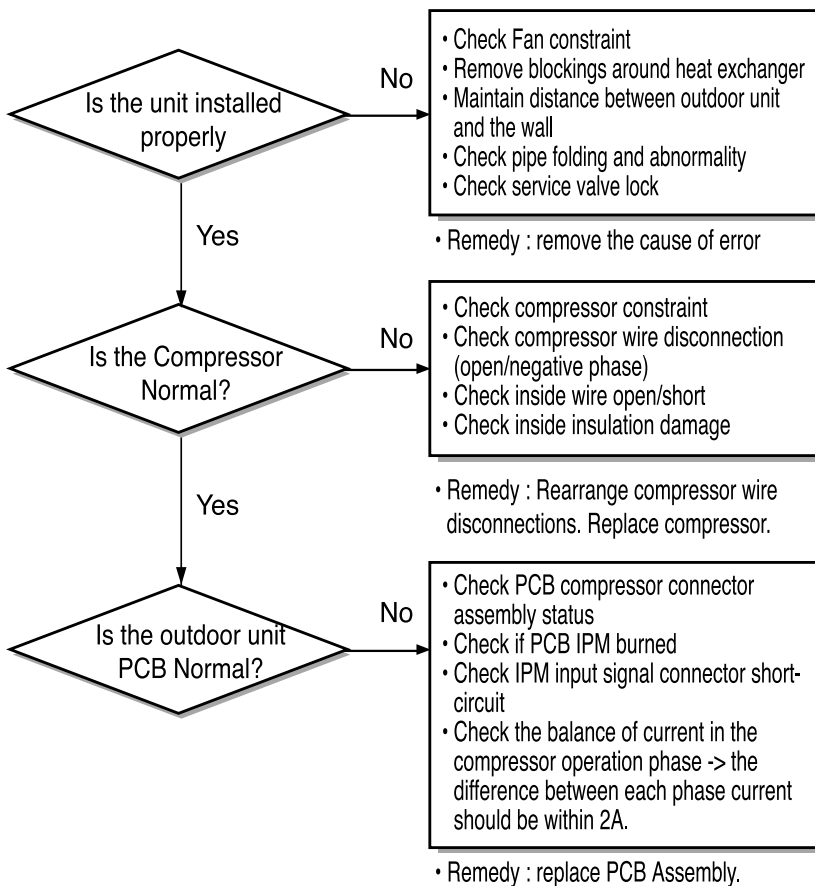

• Check for short-circuit of PCB IPM Input Signal Connector.

1. Set as the multi-tester resistance measurement mode.
2. Check the short-circuit between the input signal pins at the IPM(SPM3) lower parts in Power-off state.

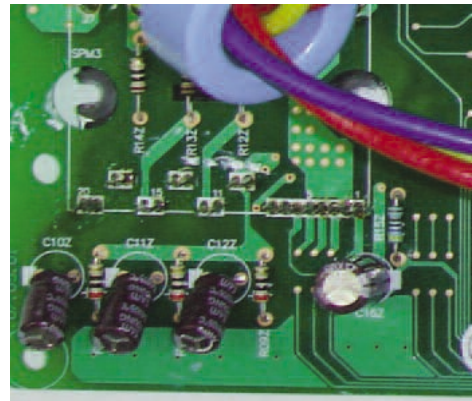

• Verifying compressor burn

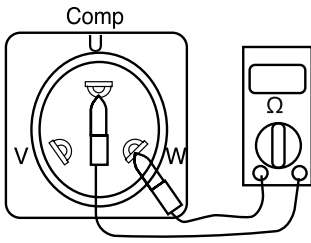

1. Remove the connectors to the PCB.
2. Measure the resistance between the lines of each terminal of the compressor. (Refer to Table 1)
3. Measure the resistance between each terminal and the chassis(pipe) of the compressor. (Refer to Table 2)
4. If the measurements are distinctively different from Table 1 and 2, the compressor is decided to be burned.

Table 1

| Resistance between the lines of each terminal | |
|---|----------|
| U - V | 0.5 ~ 1Ω |
| V - W | 0.5 ~ 1Ω |
| W - U | 0.5 ~ 1Ω |

Table 1

| Resistance of terminal insulations | |
|------------------------------------|-------|
| U - chassis | 1MΩ ↑ |
| V - chassis | 1MΩ ↑ |
| W - chassis | 1MΩ ↑ |

• Verifying IPM burn

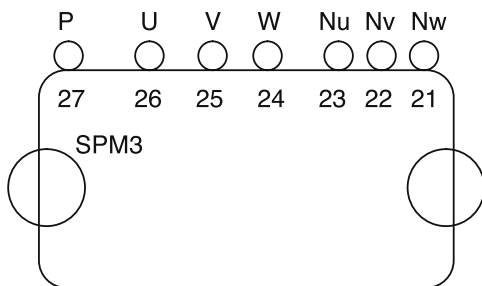

1. Remove the connectors to the PCB.
2. Set Multi-tester as Diode voltage measurement mode.
3. Measure voltages of P~U / P~V / P~W as shown in figure 1 below.
4. Measure voltages of U~Nu / V~Nu / W~Nu as shown in figure 2 below.
5. If the measurements are distinctively different as in the figures, the IPM is decided to be burned.

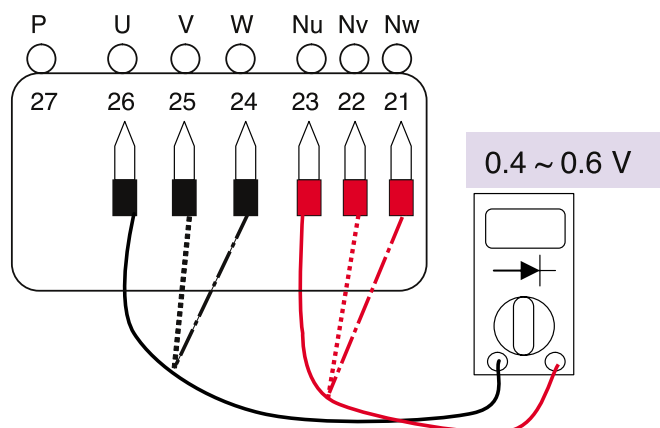
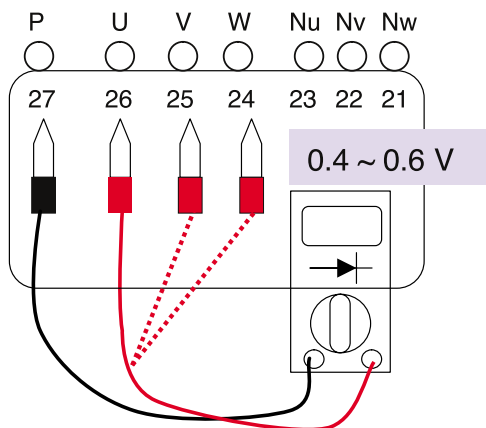
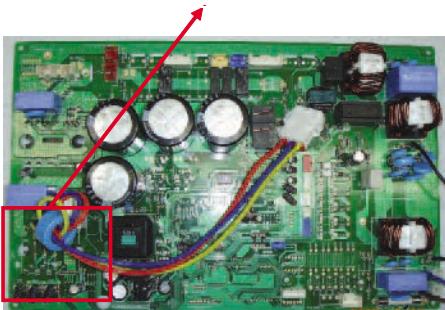

2) CH22: CT2 Error (Input Over-current)

| Inspection Number | Error Detection | Cause of Error | Check Point |
|-------------------|--|---|---|
| CH22 | AC Input current is higher than the limit. | <ul style="list-style-type: none"> • Input voltage error (low voltage) • Over load operation (Outdoor fan constraint, screened, blocked) • Burned parts inside PCB | <ul style="list-style-type: none"> • Check input voltage • Check outdoor fan constraint / screened / flow structure • Check PCB current sensor parts |

warning Before checking PCB or each outdoor electric parts, wait for 3 minutes after the power is off. When measuring at standby state of power supply, after checking the measurement mode of the meter, be careful of the short-circuits with other parts.

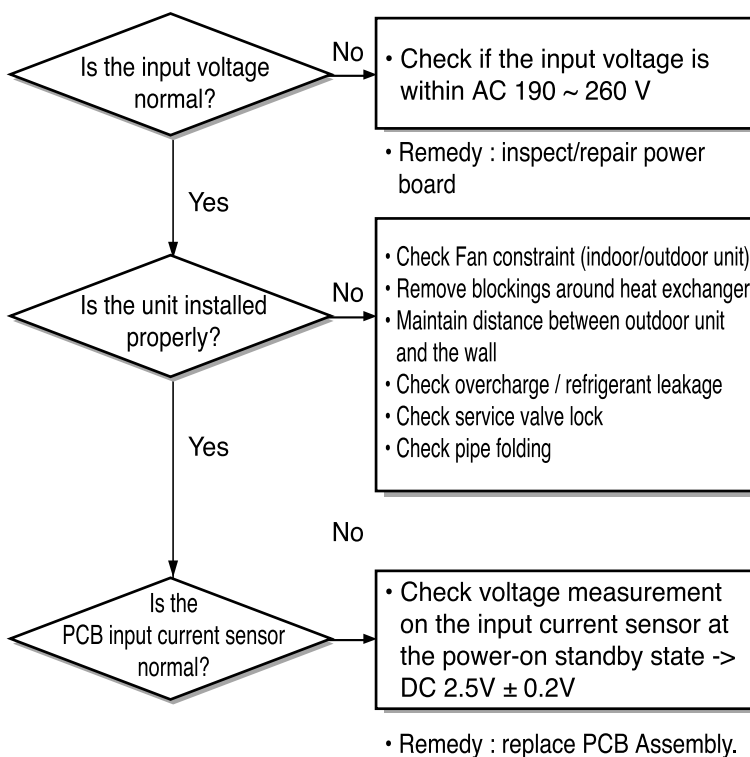

• Inspecting PCB input current sensing circuit

1. Set Multi-tester as DC voltage measurement mode.
2. Measure the measuring point DC voltages at Power-on standby state.
3. If the measurements are outside DC 2.5V ± 0.2V, the parts are decided as burned.

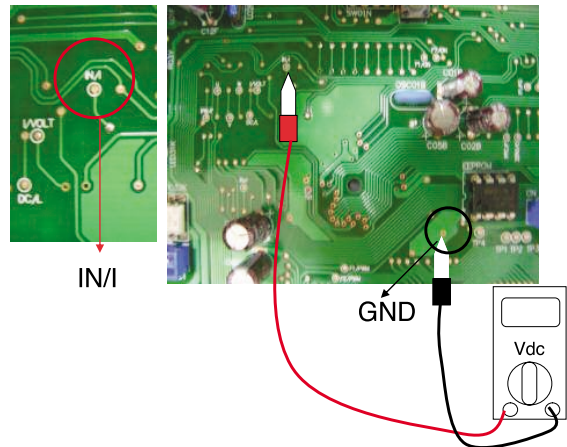

3) CH23: DC Link Low Voltage Error

| Inspection Number | Error Detection | Cause of Error | Check Point |
|-------------------|---|---|---|
| CH23 | DC Link voltage is lower than the limit. (Under DC 140Vrms) | <ul style="list-style-type: none"> Input voltage error(low voltage) Burned parts inside PCB | <ul style="list-style-type: none"> Check input voltage Check PCB DC Link voltage sensor parts |

warning Before checking PCB or each outdoor electric parts, wait for 3 minutes after the power is off. When measuring at standby state of power supply, after checking the measurement mode of the meter, be careful of the short-circuits with other parts.

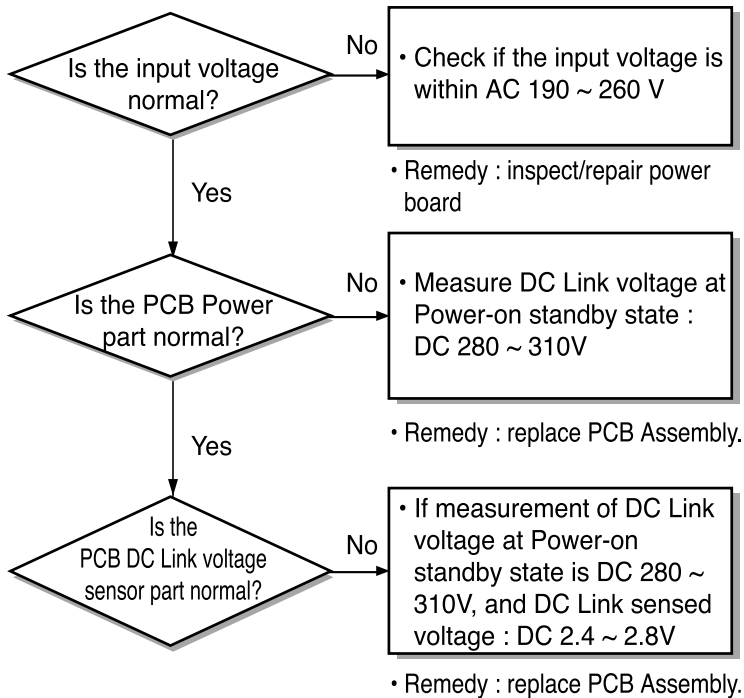

• Inspecting PCB DC Link voltage sensing circuit

1. Set Multi-tester as DC voltage measurement mode.
2. Measure the measuring point DC voltages at Power-on standby state.
3. If the measurements are outside DC 2.4 ~ 2.8V, the parts are decided as burned.

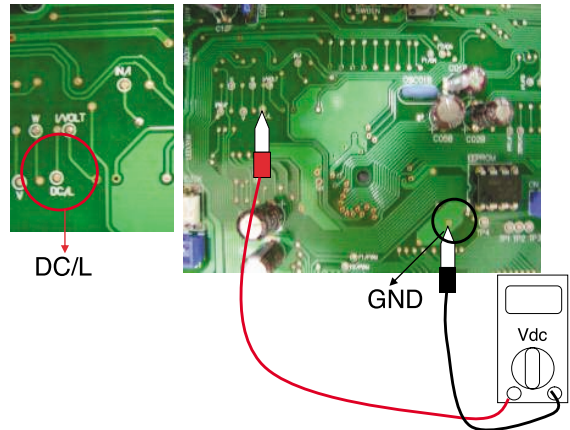

4) CH26: DC Comp Location Sensing Error

| Error Code | Error Detection | Cause of Error | Check Point |
|------------|---|--|---|
| CH26 | Over-current at the initial operation of the compressor / location sensing signal for compressor operation is not input | <ul style="list-style-type: none"> Compressor Locking Overload operation (Outdoor fan constraint, screened, blocked) Burned parts inside PCB(IPM) Burned PCB phase current sensing circuit parts | <ul style="list-style-type: none"> Check compressor locking Compressor wire open/short Check compressor insulation damage Check outdoor fan constraint / screened / flow structure Check if IMP burned (refer to CH21) Check on-PCB current sensing circuit parts |

warning

Before checking PCB or each outdoor electric parts, wait for 3 minutes after the power is off. When measuring at standby state of power supply, after checking the measurement mode of the meter, be careful of the short-circuits with other parts.

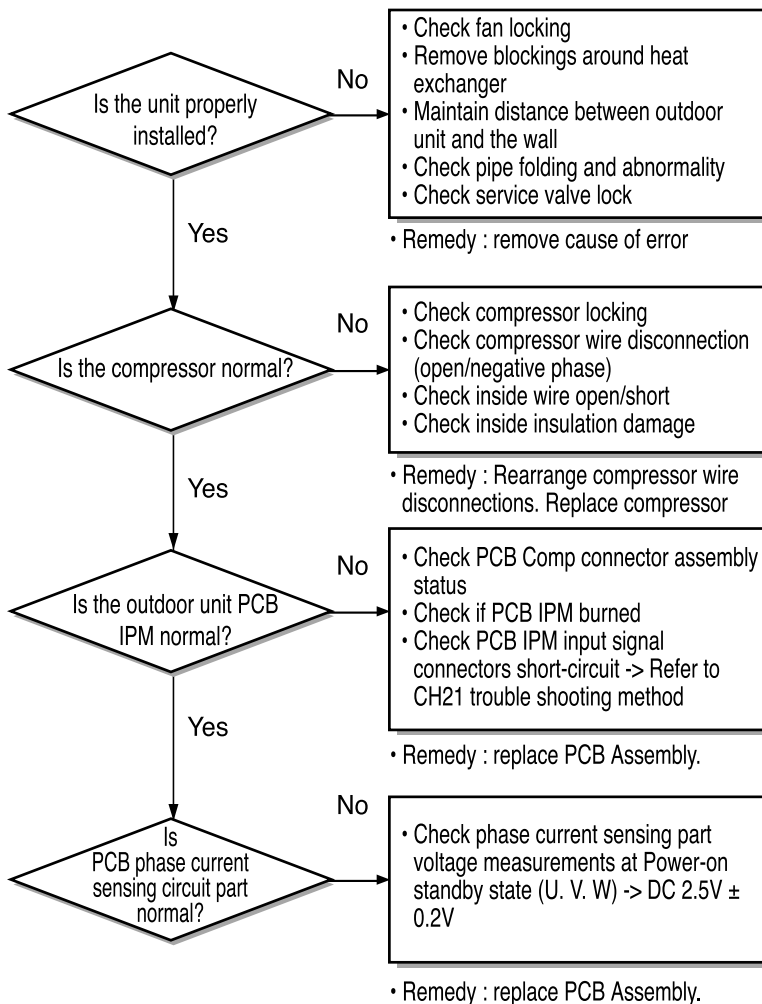

Inspecting PCB phase current sensing circuit

1. Set Multi-tester as DC voltage measurement mode.
2. Measure the below measuring point DC voltages at Power-on standby state.
3. If the measurements are outside DC 2.5V ± 0.2V, the parts are decided as burned.

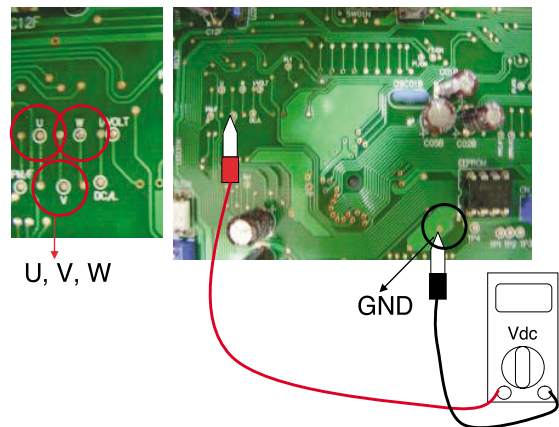

5) CH27: PSC Fault Over-current Error

| Error Code | Error Detection | Cause of Error | Check Point |
|------------|--|--|--|
| CH27 | Over-current on AC->DC converter circuit | <ul style="list-style-type: none"> • Overload operation (Outdoor fan constraint, screened, blocked) • Wrong application of Reactor Spec. • Burned PCB internal parts (PSC Module) | <ul style="list-style-type: none"> • Check outdoor fan constraint / screened / flow structure • Check Reactor Spec. : 10A/26.8mH • Check for PCB internal part burn |

warning

Before checking PCB or each outdoor electric parts, wait for 3 minutes after the power is off. When measuring at standby state of power supply, after checking the measurement mode of the meter, be careful of the short-circuits with other parts.

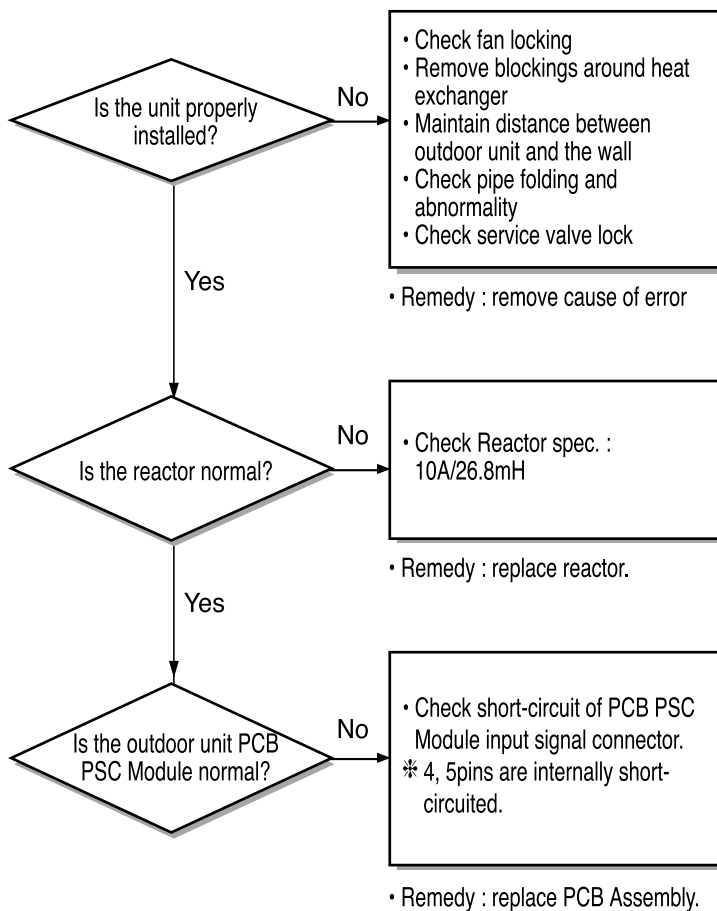

• Inspecting PCB PSC Module signal input connector short-circuit

1. Set Multi-tester as DC voltage measurement mode.
2. Check the short-circuits between PSC Module lower part input signal pins at Power-off state.

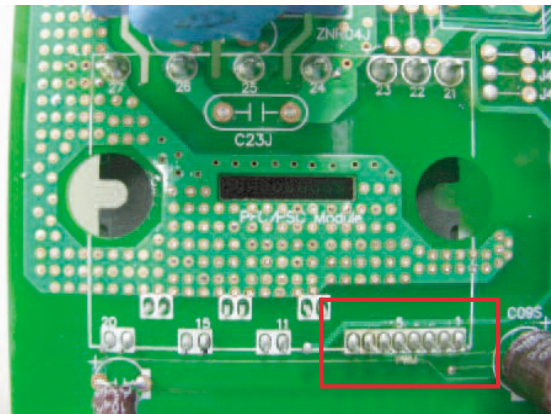

warning PSC Module 4, 5 pins are internally short-circuited

6) CH29: Compressor phase Over-current Error (only verifiable at Outdoor unit PCB Assembly)

| Error Code | Error Detection | Cause of Error | Check Point |
|------------|---|--|---|
| CH29 | Compressor input phase current is high. | <ul style="list-style-type: none"> Compressor blocked Overload operation (Outdoor fan constraint, screened, blocked) Burned PCB phase current sensor part | <ul style="list-style-type: none"> Check compressor locking Check outdoor fan constraint / screened / flow structure Check for PCB phase current sensor part |

warning

Before checking PCB or each outdoor electric parts, wait for 3 minutes after the power is off. When measuring at standby state of power supply, after checking the measurement mode of the meter, be careful of the short-circuits with other parts.

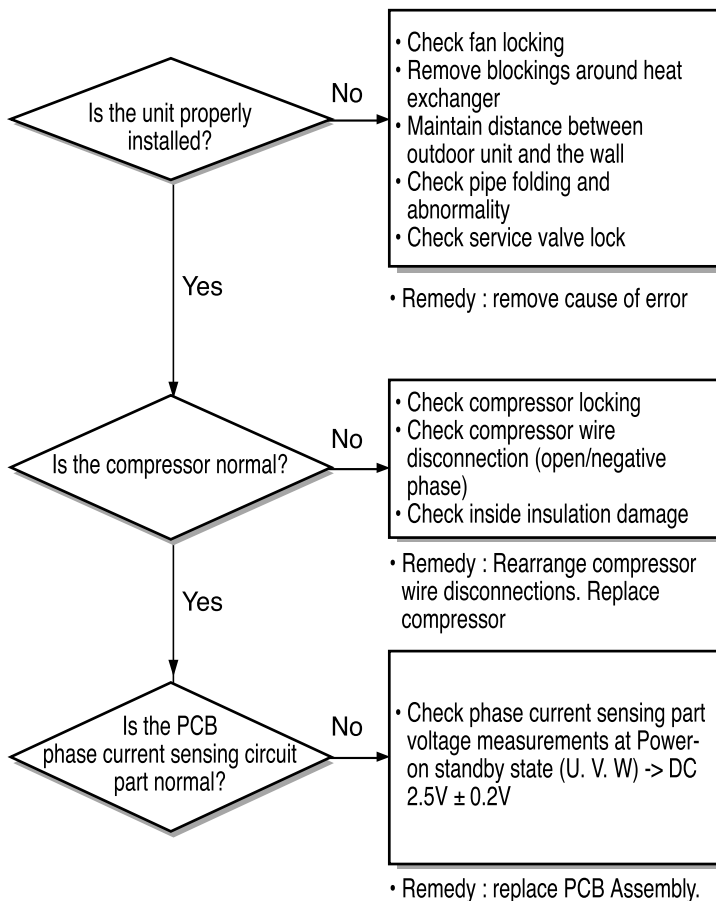

Inspecting PCB phase current sensing circuit

- Set Multi-tester as DC voltage measurement mode.
- Measure at the below measuring point DC voltages at Power-on standby state.
- If the measurements are outside DC 2.5V ± 0.2V, the parts are decided as burned.

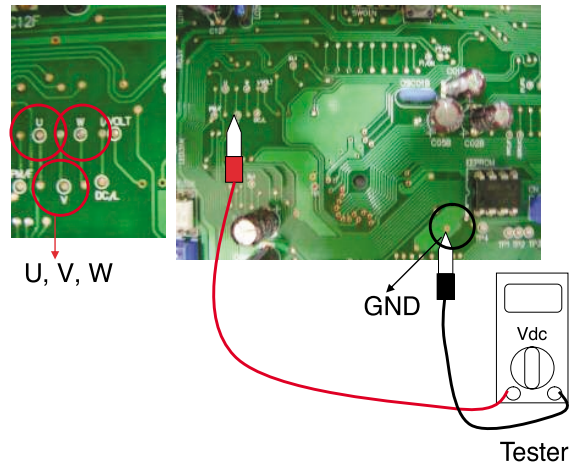

7) CH32: Inverter Compressor D-Pipe Overheat Error

| Error Code | Error Detection | Cause of Error | Check Point |
|------------|---|---|--|
| CH32 | High temperature in Discharge pipe of the inverter compressor | <ul style="list-style-type: none"> • Overload operation (Outdoor fan constraint, screened, blocked) • Refrigerant leakage (insufficient) • Poor INV Comp Discharge sensor • LEV connector displaced / poor LEV assembly | <ul style="list-style-type: none"> • Check outdoor fan constraint / screened / flow structure • Check refrigerant leakage • Check if the sensor is normal • Check the status of EEV assembly |

warning

Before checking PCB or each outdoor electric parts, wait for 3 minutes after the power is off.
When measuring at standby state of power supply, after checking the measurement mode of the meter, be careful of the short-circuits with other parts.

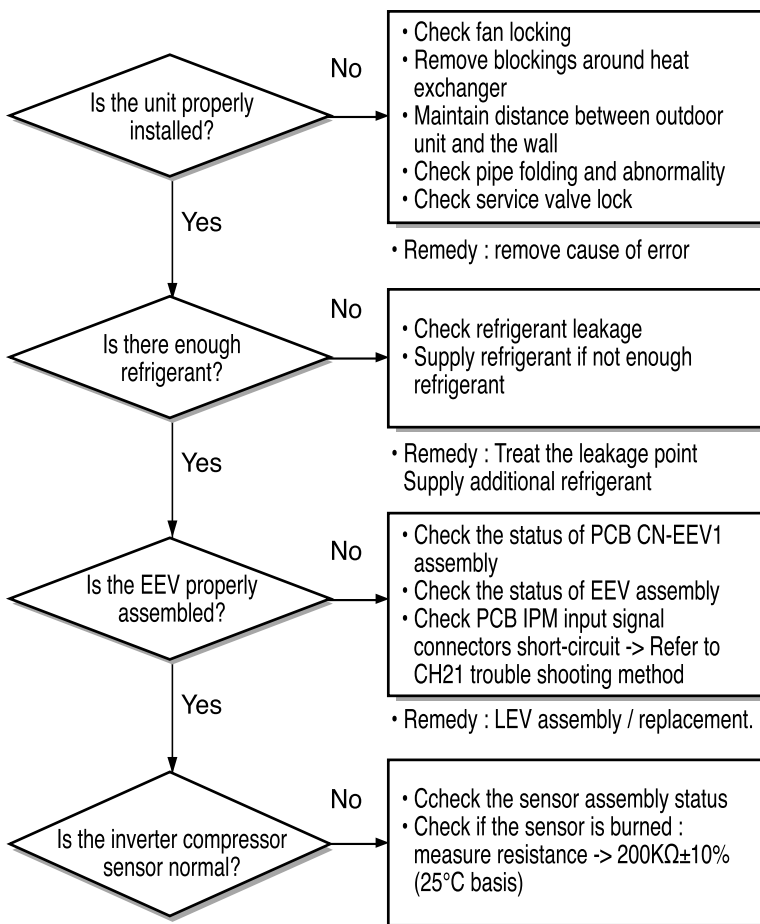

• Inspecting Inverter Compressor Discharge Sensor

1. Set Multi-tester as resistance measurement mode.
2. Measure the resistance between inverter discharge sensor connector pins.
3. Measure resistance value of $200K\Omega \pm 10\%$, 25°C basis
4. Check if the sensor insulation is damaged. -> measure the resistance between sensor connector pin and unit assembly pipe. ($1M\Omega$ or more)

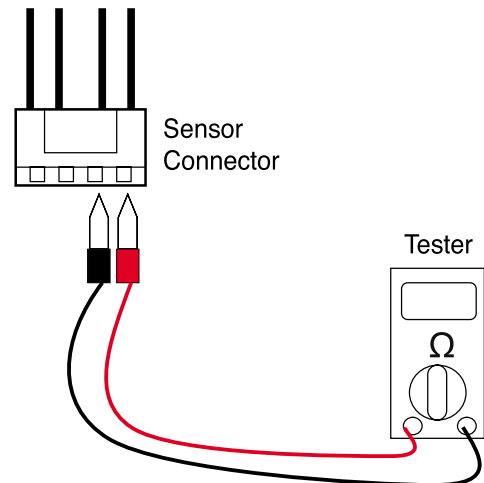

8) CH40: CT Sensor Error (Open/Short)

| Error Code | Error Detection | Cause of Error | Check Point |
|------------|--|--------------------------------------|---|
| CH40 | AC Input current / Comp phase current sensing circuit - basic voltage sensing error | • PCB sensing circuit part burned | • Check power input connector, Comp output current sensing circuit |

warning

Before checking PCB or each outdoor electric parts, wait for 3 minutes after the power is off.
When measuring at standby state of power supply, after checking the measurement mode of the meter, be careful of the short-circuits with other parts.

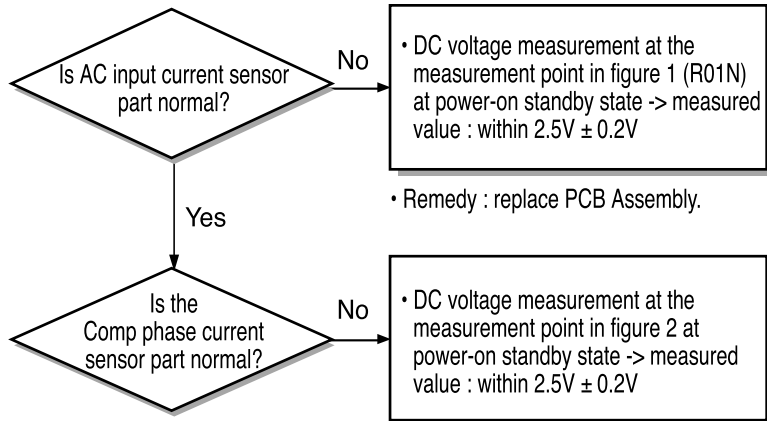

• Inspecting current sensing circuit

1. Set Multi-tester as DC voltage measurement mode.
2. DC voltage measurement at both end of R01N at power-on standby state -> measured value should be within $2.5V \pm 0.2V$
3. DC voltage measurement at the measurement point in figure 2 at power-on standby state -> measured value should be within $2.5V \pm 0.2V$

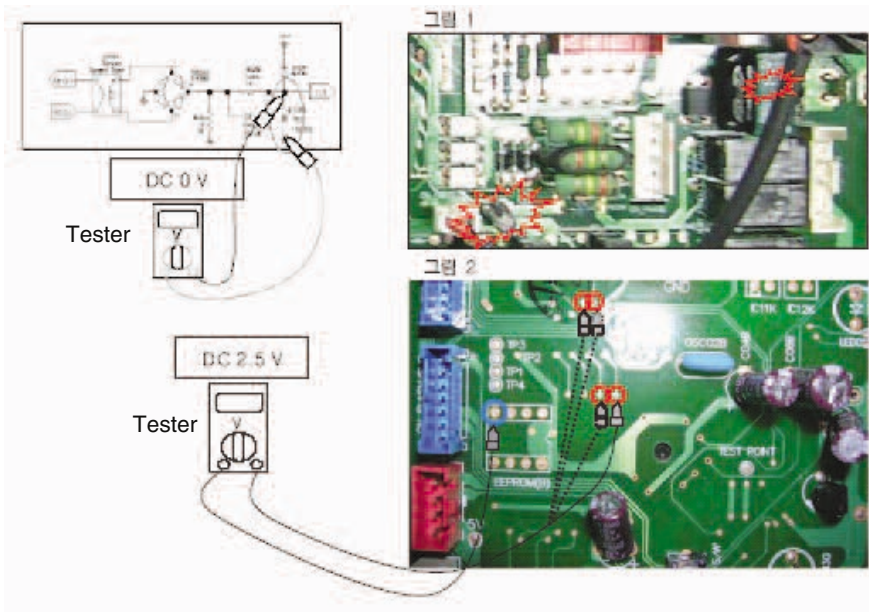

9) CH41/44/45/65: Inv D-Pipe/Outdoor Inlet/Cond. Pipe/Heat sink Sensor Error

| Error Code | Error Detection | Cause of Error | Check Point |
|------------|-------------------------------------|---|--|
| CH41 | Inv D-Pipe sensor open/short | <ul style="list-style-type: none"> • Sensor displacement (poor assembly) • Sensor burned (disconnection, insulation damage) | <ul style="list-style-type: none"> • Check the status of sensor assembly • Check if sensor is burned |
| CH44 | Outdoor Inlet sensor open/short | | |
| CH45 | Cond. Pipe sensor open/short | | |
| CH65 | B/Diode Heat sink sensor open/short | | |

warning Before checking PCB or each outdoor electric parts, wait for 3 minutes after the power is off. When measuring at standby state of power supply, after checking the measurement mode of the meter, be careful of the short-circuits with other parts.

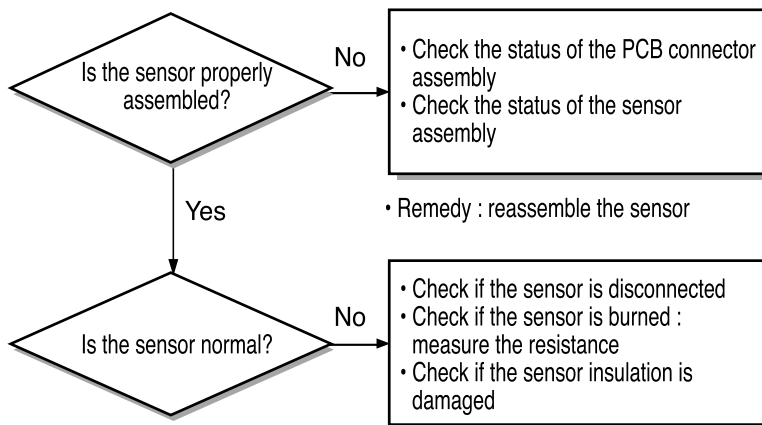

• Inspecting Inverter Compressor Discharge Sensor

1. Set Multi-tester as resistance measurement mode.
2. Measure resistance between the sensor connectors
3. Check if the sensor insulation is damaged -> Measure resistance between sensor connector pin and the unit assembly pipe. (1MΩ or more)

| Sensor Resistance Value (25°C basis) | |
|--------------------------------------|------|
| Inv D-Pipe Sensor | 200k |
| Outdoor Inlet Sensor | 10k |
| Cond. Pipe Sensor | 5k |
| B/Diode Heat Sink Sensor | 10k |

10) CH53: Outdoor Unit <-> Indoor Unit Communication Error

| Error Code | Error Detection | Cause of Error | Check Point |
|------------|--|--|--|
| CH53 | If the data transmitted by the indoor unit is not received for 3 minutes continuously. | <ul style="list-style-type: none"> No power on indoor unit Indoor/outdoor unit Power connection error / communication line not installed Communication error caused by external noise Indoor/outdoor unit communication circuit parts burned | <ul style="list-style-type: none"> Check indoor unit power status Check indoor/outdoor unit power/communication line disconnection Check the status of indoor/outdoor unit ground connections Check if outdoor unit communication parts are burned |

warning Before checking PCB or each outdoor electric parts, wait for 3 minutes after the power is off. When measuring at standby state of power supply, after checking the measurement mode of the meter, be careful of the short-circuits with other parts.

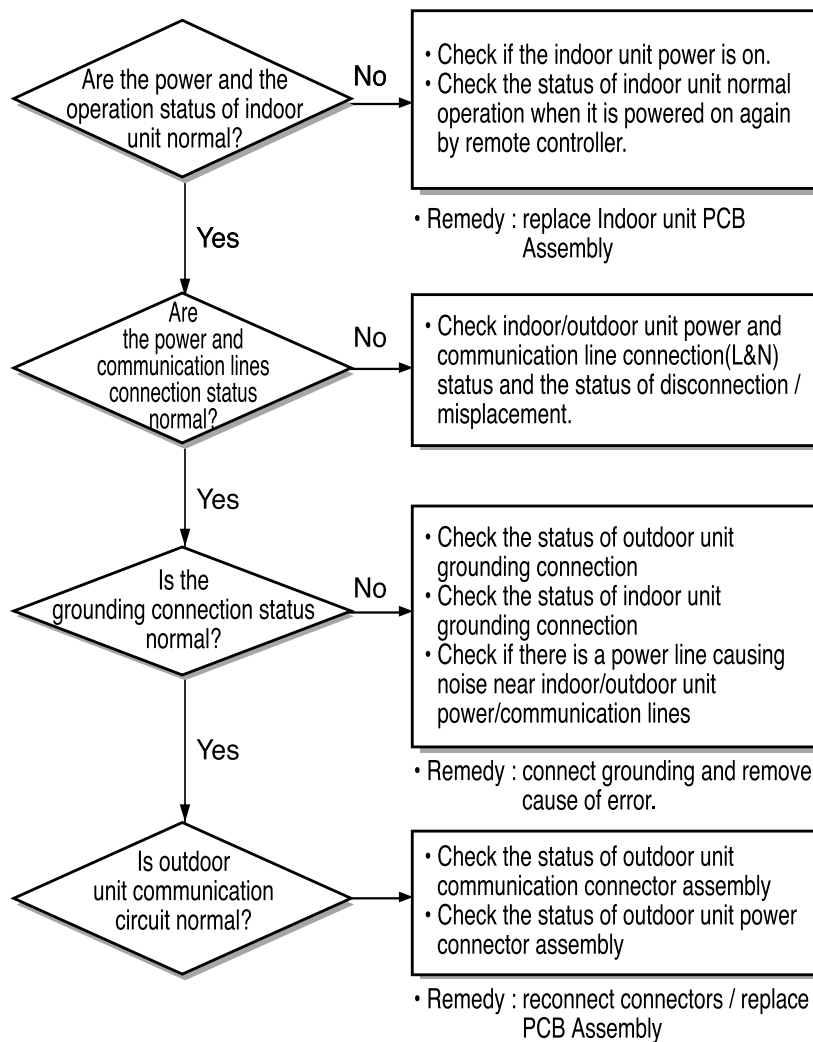

11) CH60: Outdoor Unit PCB EEPROM Error

| Error Code | Error Detection | Cause of Error | Check Point |
|------------|---|---|-----------------|
| CH60 | Incorrect checksum of outdoor unit PCB EEPROM | <ul style="list-style-type: none"> Outdoor unit PCB EEPROM misapplied Outdoor unit PCB EEPROM poor assembly | EEPROM assembly |

warning Before checking PCB or each outdoor electric parts, wait for 3 minutes after the power is off. When measuring at standby state of power supply, after checking the measurement mode of the meter, be careful of the short-circuits with other parts.

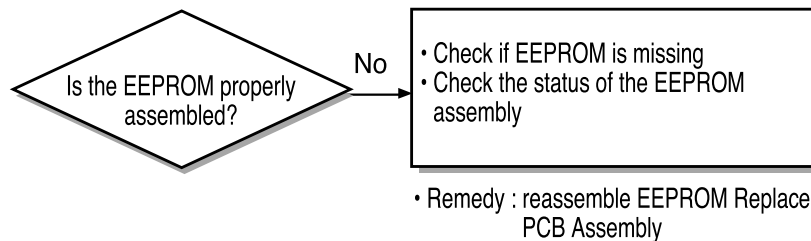

• Inspecting Outdoor EEPROM Assembly Status

1. Check the consistency of the EEPROM's direction inserted in the socket and the EEPROM marking.
2. Check if the EEPROM is securely inserted in the socket. (poor connection)
3. Check if the EEPROM Lead Pin is missing in the socket.

EEPROM ←

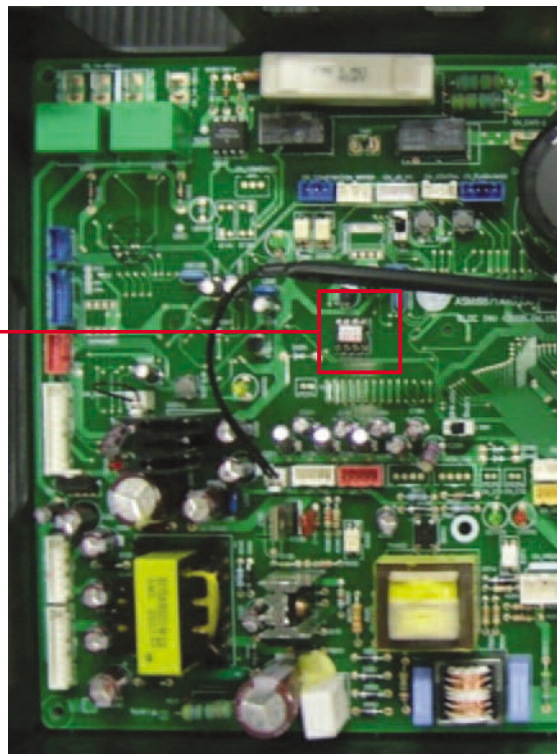

12) CH61: Cond. Pipe Overheat Error

| Error Code | Error Detection | Cause of Error | Check Point |
|------------|--|---|--|
| CH61 | High temperature in outdoor Cond. Pipe | <ul style="list-style-type: none"> • Overload operation (Outdoor fan constraint, screened, blocked) • Outdoor unit heat exchanger contaminated • EEV connector displaced / poor EEV assembly • Poor Cond. Pipe sensor assembly / burned | <ul style="list-style-type: none"> • Check outdoor fan constraint / screened / flow structure • Check if refrigerant overcharged • Check the status of EEV assembly • Check the status of sensor assembly / burn |

warning Before checking PCB or each outdoor electric parts, wait for 3 minutes after the power is off. When measuring at standby state of power supply, after checking the measurement mode of the meter, be careful of the short-circuits with other parts.

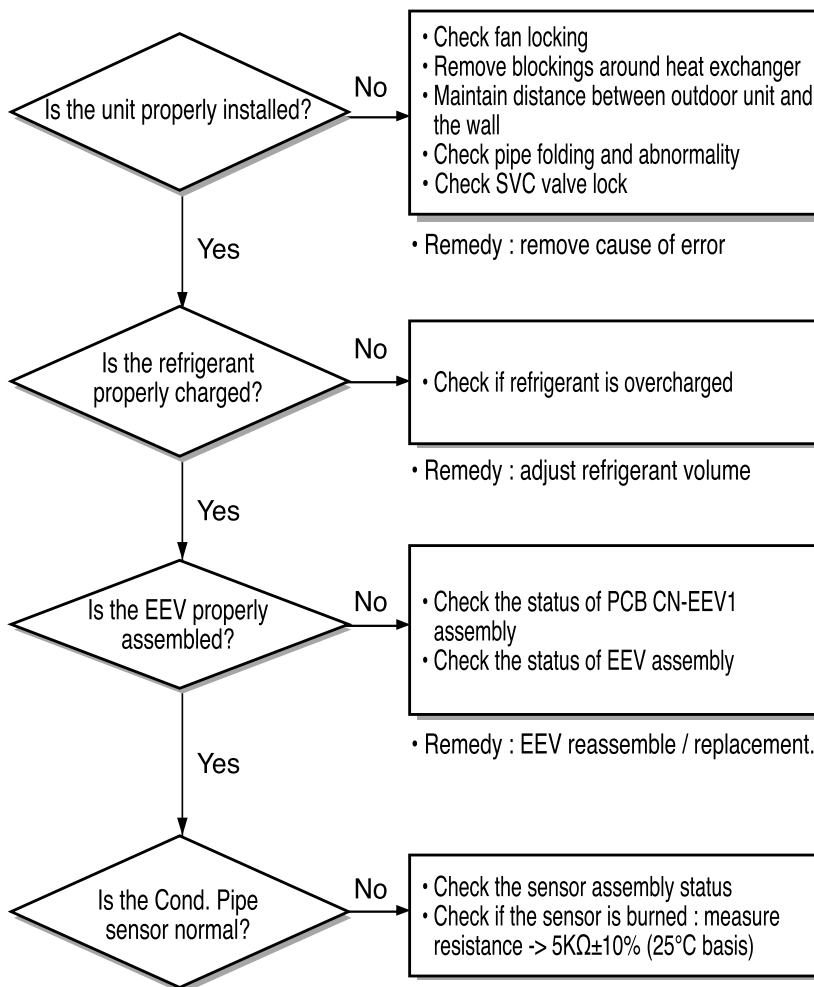

• Inspecting Cond. Pipe Sensor

1. Set Multi-tester as resistance measurement mode.
2. Measure the resistance between rated speed Comp Discharge sensor connector pins.
3. Measure resistance value of $5k\Omega \pm 10\%$, 25°C basis
4. Check if the sensor insulation is damaged. -> measure the resistance between sensor connector pin and unit assembly pipe. ($1M\Omega$ or more)

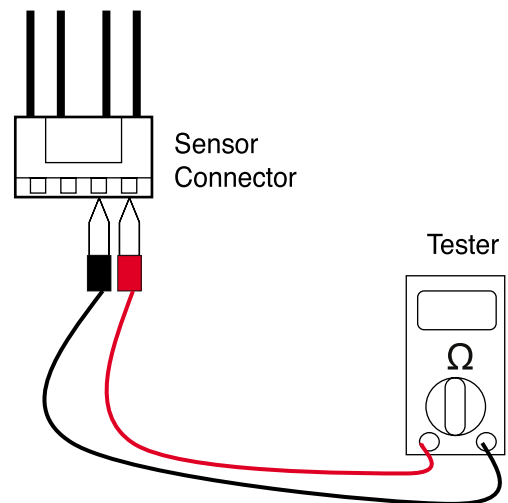

13) CH62: Heat Sink Overheat Error

| Error Code | Error Detection | Cause of Error | Check Point |
|------------|---|---|---|
| CH62 | High temperature in outdoor PCB Heat Sink | <ul style="list-style-type: none"> • Overload operation (Outdoor fan constraint, screened, blocked) • Poor PCB Heat Sink assembly • Poor PCB temperature sensing circuit parts | <ul style="list-style-type: none"> • Check outdoor fan constraint / screened / flow structure • Check for the status of the PCB Heat sink connection • Check PCB temperature sensing parts |

warning

Before checking PCB or each outdoor electric parts, wait for 3 minutes after the power is off. When measuring at standby state of power supply, after checking the measurement mode of the meter, be careful of the short-circuits with other parts.

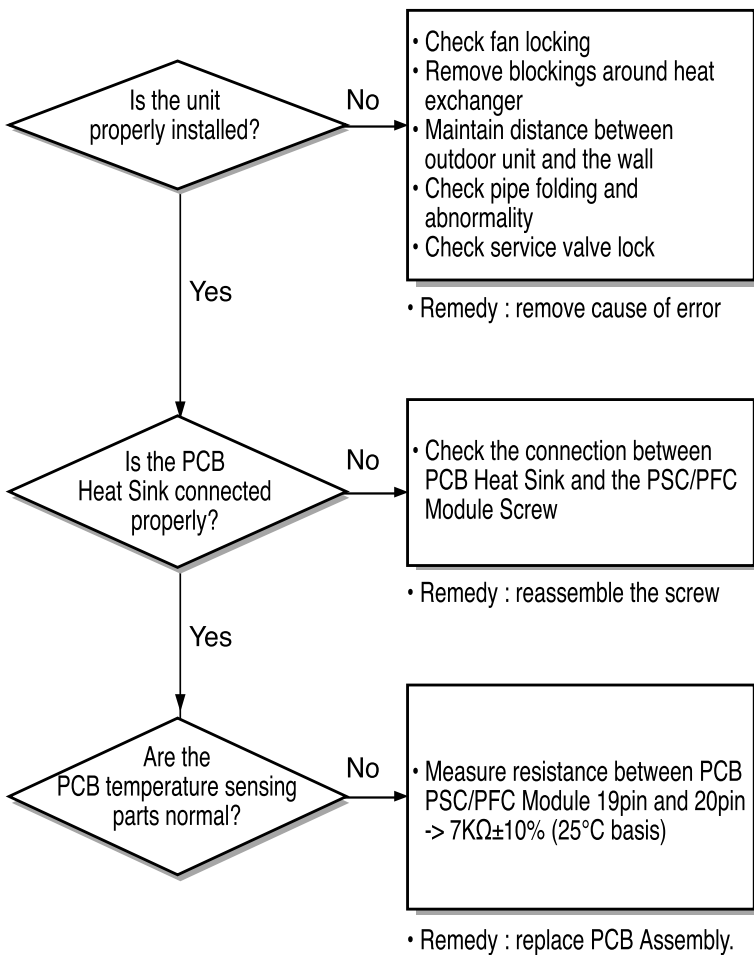

• Inspecting PCB PSC/PFC Module temperature sensing part

1. Set Multi-tester as resistance measurement mode.
2. Measure resistance between PSC/PFC Module pins 19 ~ 20 at power off state.
3. Measured resistance value of $7K\Omega \pm 10\%$, $25^{\circ}C$ basis

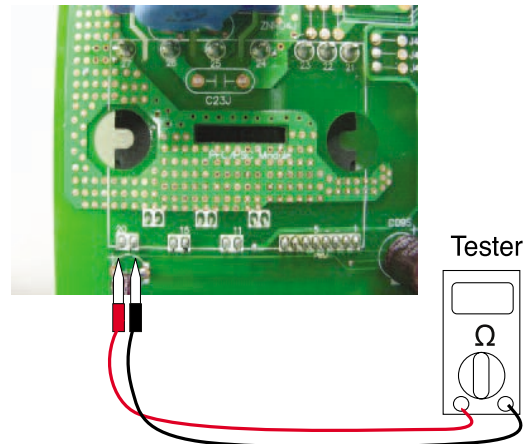

14) CH67: Outdoor BLDC Fan Lock Error

| Error Code | Error Detection | Cause of Error | Check Point |
|------------|--|--|---|
| CH67 | The outdoor unit BLDC Fan operation F/Back signal does not come on | <ul style="list-style-type: none"> Outdoor BLDC Fan Lock PCB Fan connector displaced BLDC Fan motor burned / wire disconnected PCB BLDC Fan operation circuit burned | <ul style="list-style-type: none"> Check for the status of outdoor fan assembly Check for the status of the PCB Fan connector assembly Check Fan motor wire disconnection Check if Fan motor burned |

warning Before checking PCB or each outdoor electric parts, wait for 3 minutes after the power is off. When measuring at standby state of power supply, after checking the measurement mode of the meter, be careful of the short-circuits with other parts.

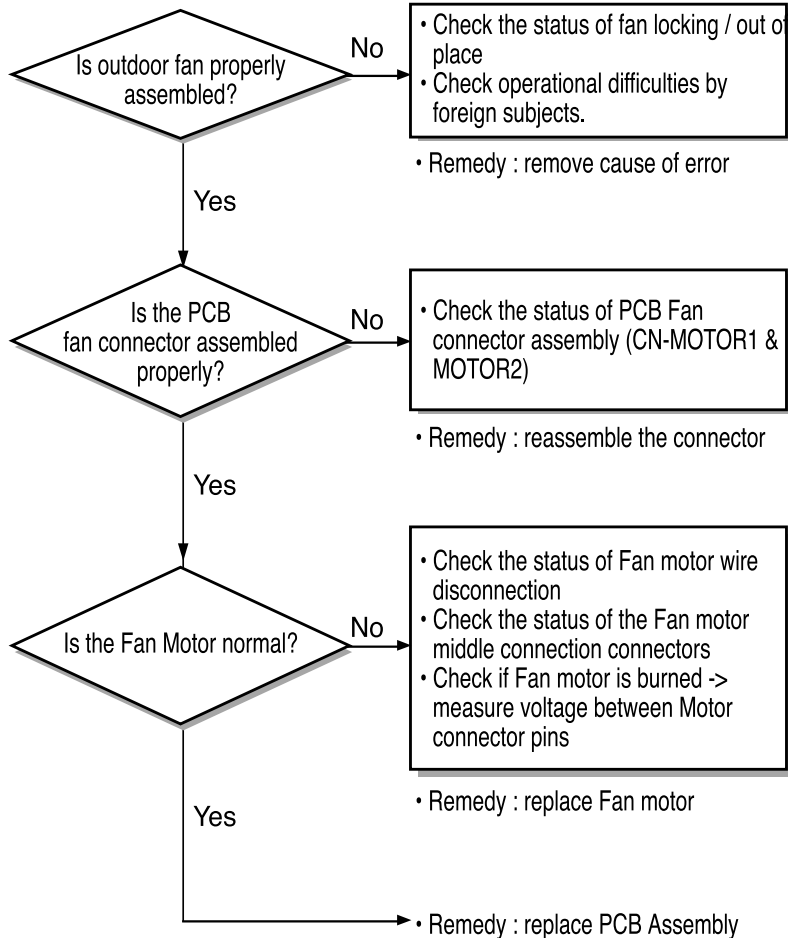

Inspecting Outdoor BLDC Fan Motor burn

1. Set Multi-tester as Diode voltage measurement mode.
2. Measure voltage between Fan motor connector pin 1 and pin 4 at power off state.
3. Measured voltage value of $1V \pm 0.2V$ means the motor is internally burned.

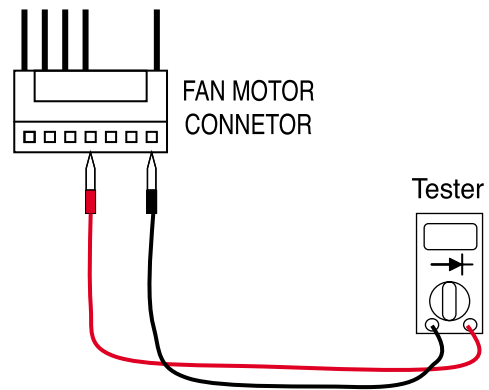

■ Trouble Shooting Guide [Outdoor Unit(1 LED Type)]

1) CH21: DC Peak Error

| Inspection Number | Error Detection | Cause of Error | Check Point |
|-------------------|----------------------------------|---|--|
| CH21 | High current into the compressor | <ul style="list-style-type: none"> • Compressor blocked • Disconnection/short-circuit inside compressor • Over load operation (Outdoor fan constraint, screened, blocked) • Burned parts inside PCB | <ul style="list-style-type: none"> • Check compressor constraint • Check compressor wire open/short • Check compressor insulation damage • Check outdoor fan constraint / screened / flow structure • Check if IPM burned |

warning

Before checking PCB or each outdoor electric parts, wait for 3 minutes after the power is off. When measuring at standby state of power supply, after checking the measurement mode of the meter, be careful of the short-circuits with other parts.

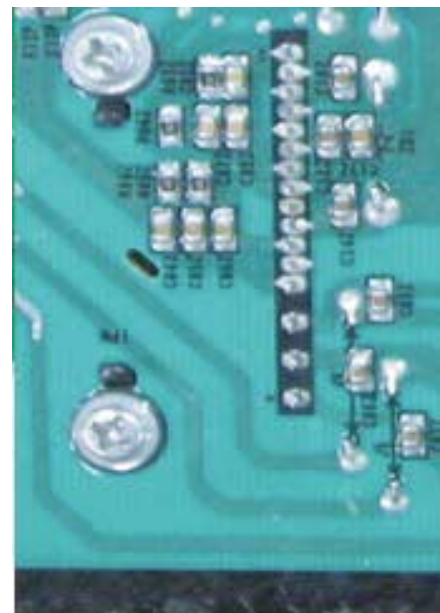
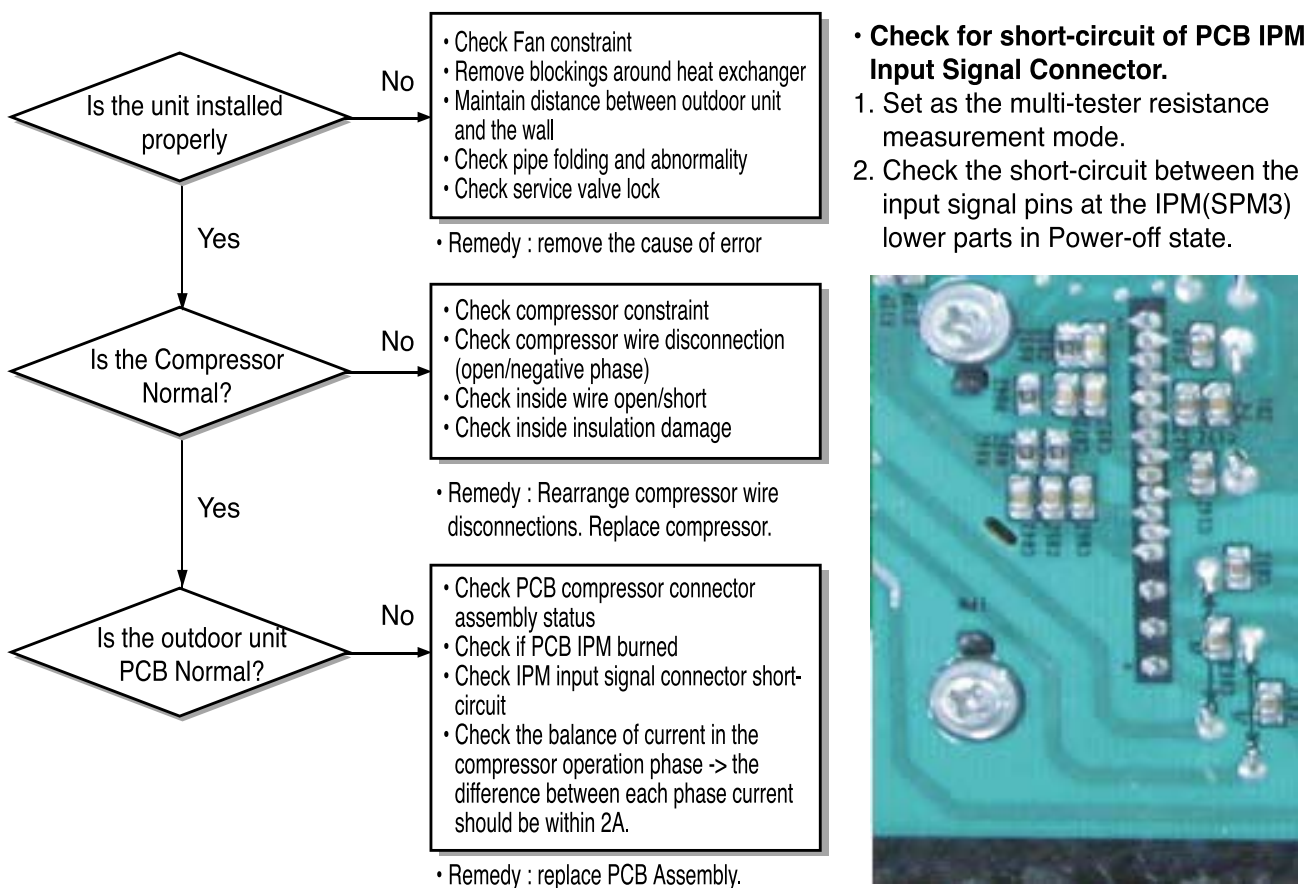

• Verifying compressor burn

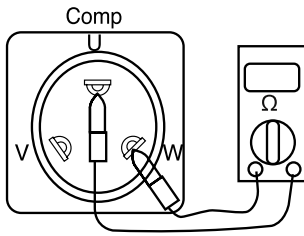

1. Remove the connectors to the PCB.
2. Measure the resistance between the lines of each terminal of the compressor. (Refer to Table 1)
3. Measure the resistance between each terminal and the chassis(pipe) of the compressor. (Refer to Table 2)
4. If the measurements are distinctively different from Table 1 and 2, the compressor is decided to be burned.

Table 1

| Resistance between the lines of each | |
|--------------------------------------|----------|
| U - V | 1.5 ~ 2Ω |
| V - W | 1.5 ~ 2Ω |
| W - U | 1.5 ~ 2Ω |

Table 1

| Resistance of terminal insulations | |
|------------------------------------|-------|
| U - chassis | 1MΩ ↑ |
| V - chassis | 1MΩ ↑ |
| W - chassis | 1MΩ ↑ |

• Verifying IPM burn

1. Remove the connectors to the PCB.
2. Set Multi-tester as Diode voltage measurement mode.
3. Measure voltages of P~U / P~V / P~W as shown in figure 1 below.
4. Measure voltages of U~Nu / V~Nu / W~Nu as shown in figure 2 below.
5. If the measurements are distinctively different as in the figures, the IPM is decided to be burned.



[IPM 위치 및 Pin 번호]♪

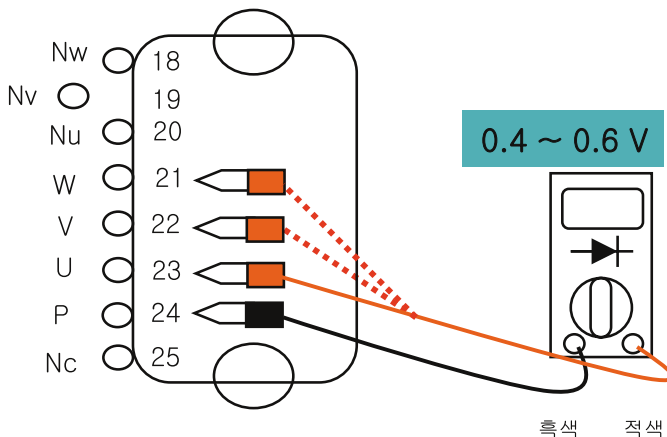
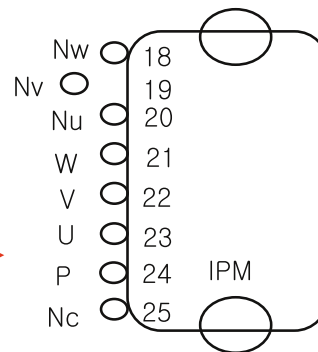

[Figure 1]

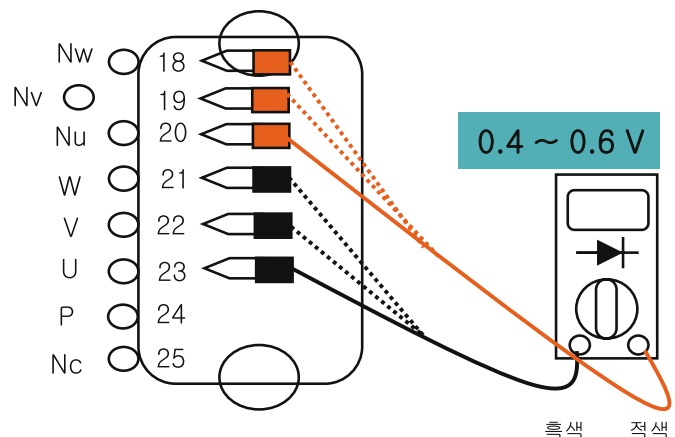

[Figure 2]

2) CH22: CT2 Error (Input Over-current)

| Inspection Number | Error Detection | Cause of Error | Check Point |
|-------------------|--|---|---|
| CH22 | AC Input current is higher than the limit. | <ul style="list-style-type: none"> • Input voltage error (low voltage) • Over load operation (Outdoor fan constraint, screened, blocked) • Burned parts inside PCB | <ul style="list-style-type: none"> • Check input voltage • Check outdoor fan constraint / screened / flow structure • Check PCB current sensor parts |

warning

Before checking PCB or each outdoor electric parts, wait for 3 minutes after the power is off. When measuring at standby state of power supply, after checking the measurement mode of the meter, be careful of the short-circuits with other parts.

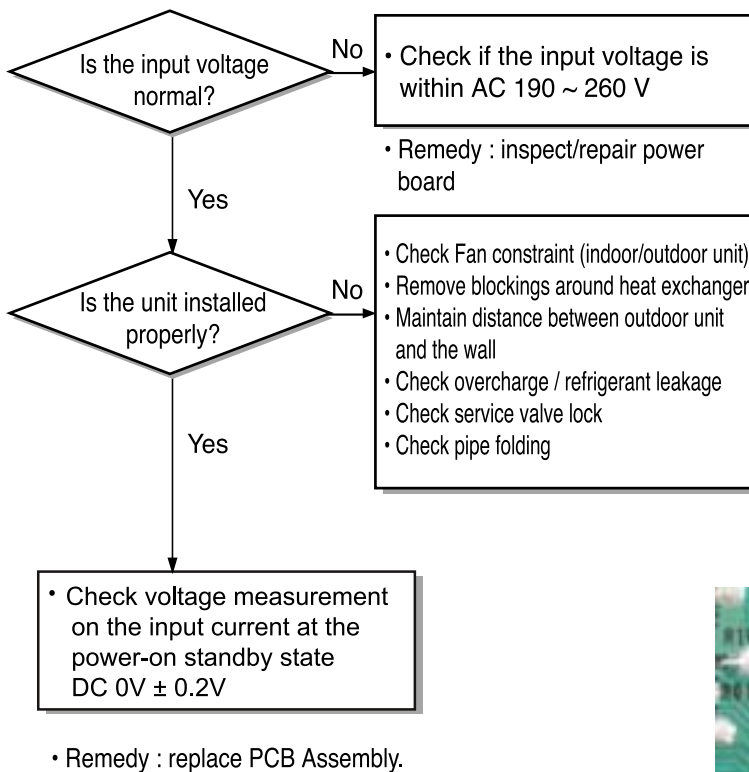

• Inspecting PCB input current sensing circuit

1. Set Multi-tester as DC voltage measurement mode.
2. Measure the measuring point DC voltages at Power-on standby state.
3. If the measurements are outside DC $2.5V \pm 0.2V$, the parts are decided as burned.

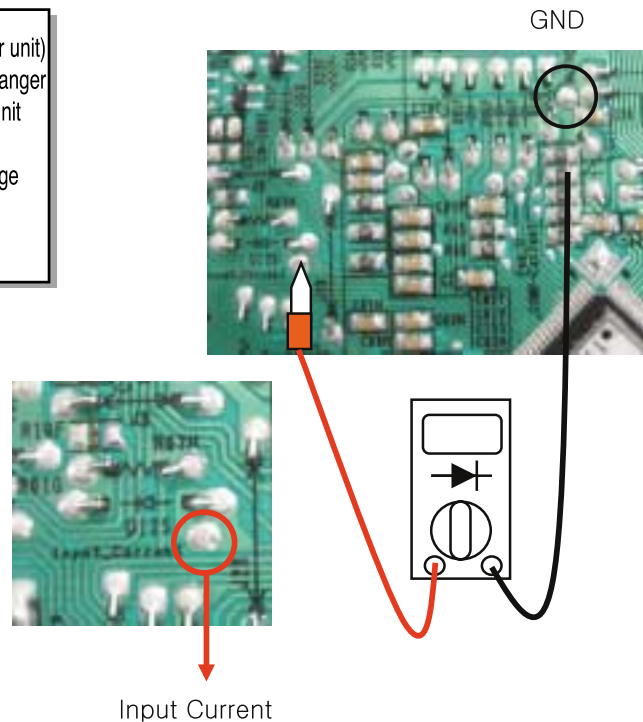

3) CH23: DC Link Low Voltage Error

| Inspection Number | Error Detection | Cause of Error | Check Point |
|-------------------|---|---|---|
| CH23 | DC Link voltage is lower than the limit. (Under DC 140Vrms) | <ul style="list-style-type: none"> Input voltage error(low voltage) Burned parts inside PCB | <ul style="list-style-type: none"> Check input voltage Check PCB DC Link voltage sensor parts |

warning

Before checking PCB or each outdoor electric parts, wait for 3 minutes after the power is off. When measuring at standby state of power supply, after checking the measurement mode of the meter, be careful of the short-circuits with other parts.

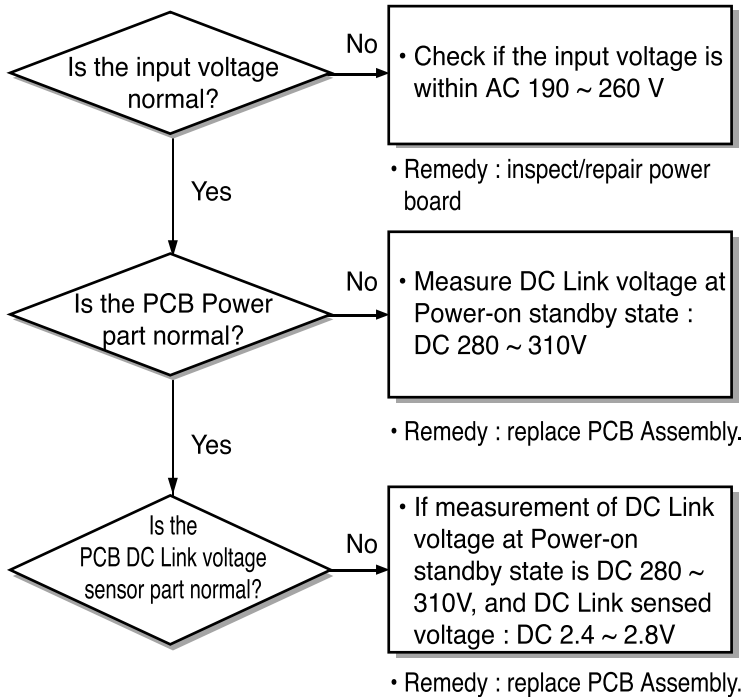

Inspecting PCB DC Link voltage sensing circuit

1. Set Multi-tester as DC voltage measurement mode.
2. Measure the measuring point DC voltages at Power-on standby state.
3. If the measurements are outside DC 2.4 ~ 2.8V, the parts are decided as burned.

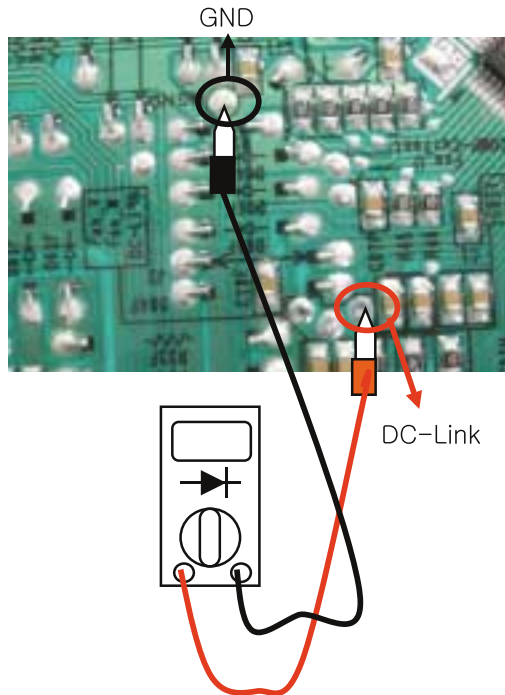

4) CH26: DC Comp Location Sensing Error

| Error Code | Error Detection | Cause of Error | Check Point |
|------------|---|--|---|
| CH26 | Over-current at the initial operation of the compressor / location sensing signal for compressor operation is not input | <ul style="list-style-type: none"> Compressor Locking Overload operation (Outdoor fan constraint, screened, blocked) Burned parts inside PCB(IPM) Burned PCB phase current sensing circuit parts | <ul style="list-style-type: none"> Check compressor locking Compressor wire open/short Check compressor insulation damage Check outdoor fan constraint / screened / flow structure Check if IMP burned (refer to CH21) Check on-PCB current sensing circuit parts |

warning

Before checking PCB or each outdoor electric parts, wait for 3 minutes after the power is off. When measuring at standby state of power supply, after checking the measurement mode of the meter, be careful of the short-circuits with other parts.

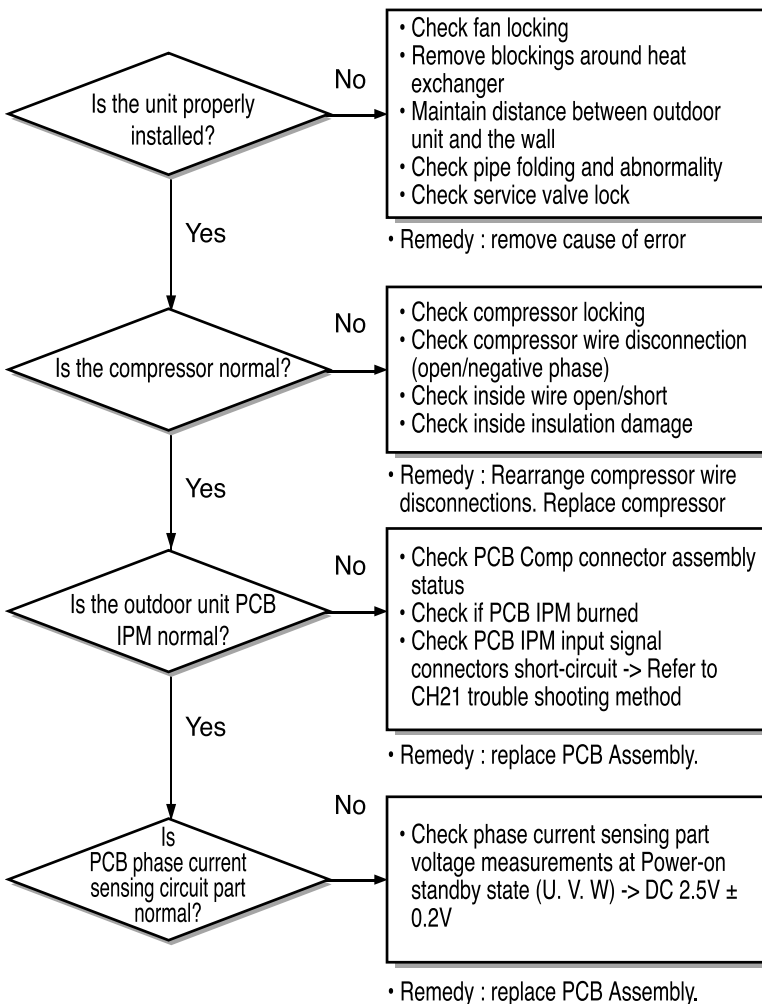

Inspecting PCB phase current sensing circuit

1. Set Multi-tester as DC voltage measurement mode.
2. Measure the below measuring point DC voltages at Power-on standby state.
3. If the measurements are outside DC 2.5V ± 0.2V, the parts are decided as burned.

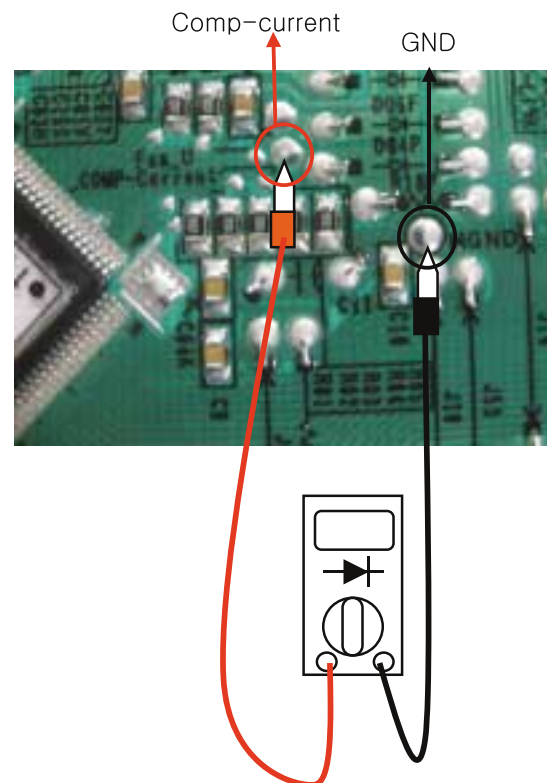

5) CH29: Compressor phase Over-current Error (only verifiable at Outdoor unit PCB Assembly)

| Error Code | Error Detection | Cause of Error | Check Point |
|------------|---|--|---|
| CH29 | Compressor input phase current is high. | <ul style="list-style-type: none"> Compressor blocked Overload operation (Outdoor fan constraint, screened, blocked) Burned PCB phase current sensor part | <ul style="list-style-type: none"> Check compressor locking Check outdoor fan constraint / screened / flow structure Check for PCB phase current sensor part |

warning

Before checking PCB or each outdoor electric parts, wait for 3 minutes after the power is off. When measuring at standby state of power supply, after checking the measurement mode of the meter, be careful of the short-circuits with other parts.

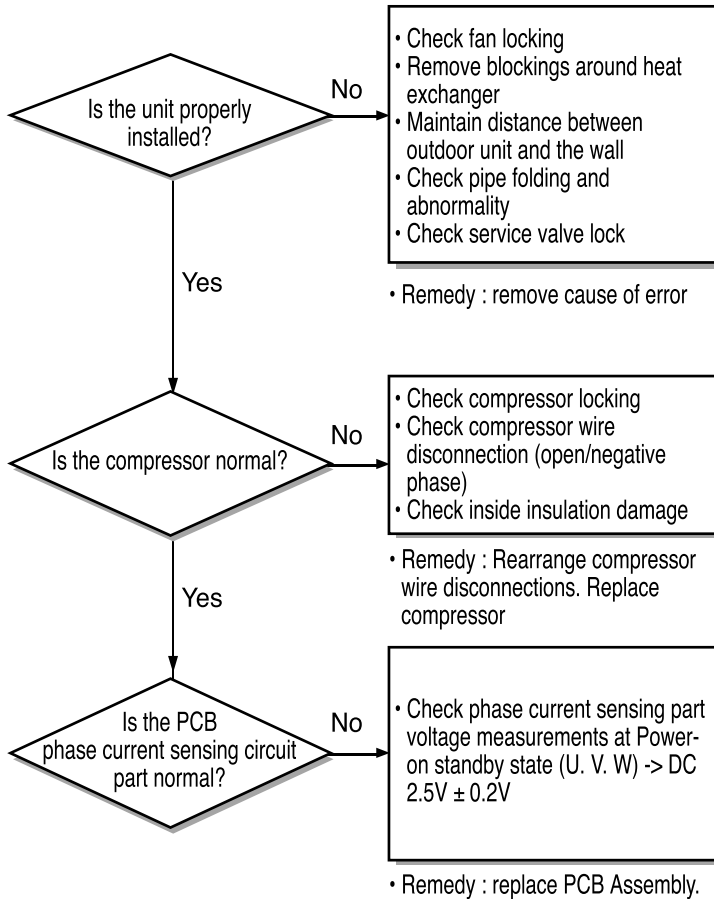

Inspecting PCB phase current sensing circuit

- Set Multi-tester as DC voltage measurement mode.
- Measure at the below measuring point DC voltages at Power-on standby state.
- If the measurements are outside DC $2.5V \pm 0.2V$, the parts are decided as burned.

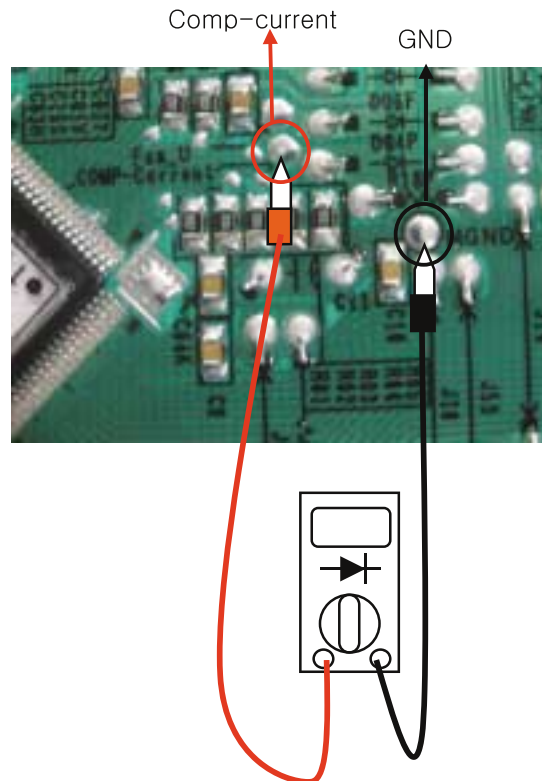

6) CH32: Inverter Compressor D-Pipe Overheat Error

| Error Code | Error Detection | Cause of Error | Check Point |
|------------|---|---|--|
| CH32 | High temperature in Discharge pipe of the inverter compressor | <ul style="list-style-type: none"> • Overload operation (Outdoor fan constraint, screened, blocked) • Refrigerant leakage (insufficient) • Poor INV Comp Discharge sensor • LEV connector displaced / poor LEV assembly | <ul style="list-style-type: none"> • Check outdoor fan constraint / screened / flow structure • Check refrigerant leakage • Check if the sensor is normal • Check the status of EEV assembly |

warning

Before checking PCB or each outdoor electric parts, wait for 3 minutes after the power is off. When measuring at standby state of power supply, after checking the measurement mode of the meter, be careful of the short-circuits with other parts.

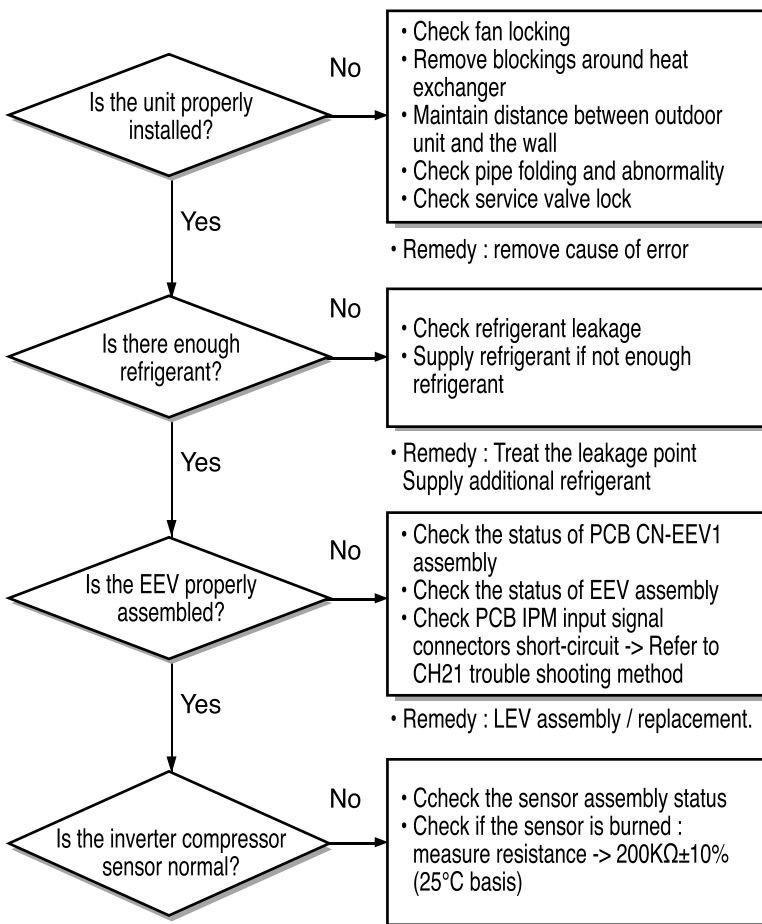

• Inspecting Inverter Compressor Discharge Sensor

1. Set Multi-tester as resistance measurement mode.
2. Measure the resistance between inverter discharge sensor connector pins.
3. Measure resistance value of $200\text{K}\Omega \pm 10\%$, 25°C basis
4. Check if the sensor insulation is damaged. -> measure the resistance between sensor connector pin and unit assembly pipe. ($1\text{M}\Omega$ or more)

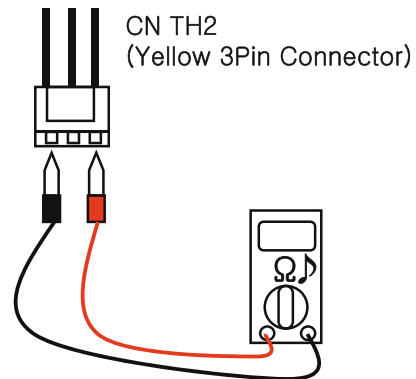

7) CH40: CT Sensor Error (Open/Short)

| Error Code | Error Detection | Cause of Error | Check Point |
|------------|---|-----------------------------------|--|
| CH40 | AC Input current / Comp phase current sensing circuit - basic voltage sensing error | • PCB sensing circuit part burned | • Check power input connector, Comp output current sensing circuit |

warning Before checking PCB or each outdoor electric parts, wait for 3 minutes after the power is off. When measuring at standby state of power supply, after checking the measurement mode of the meter, be careful of the short-circuits with other parts.

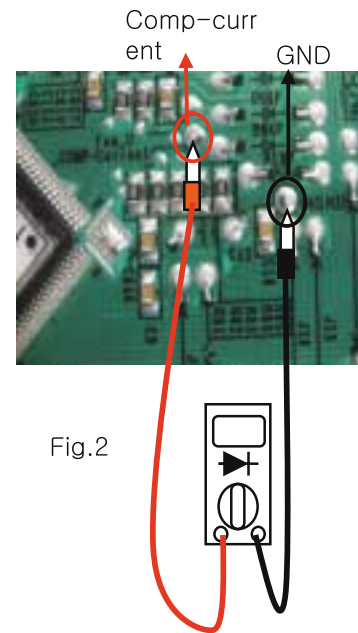
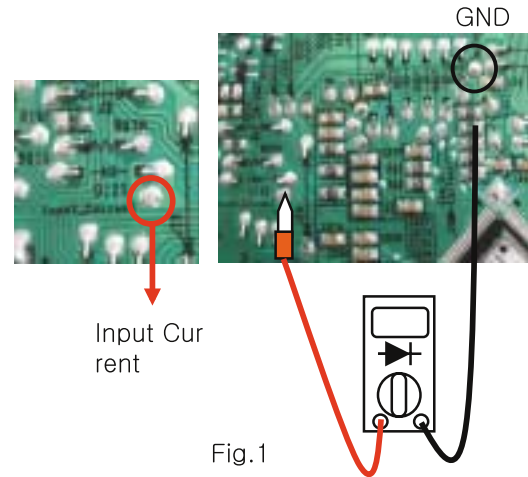
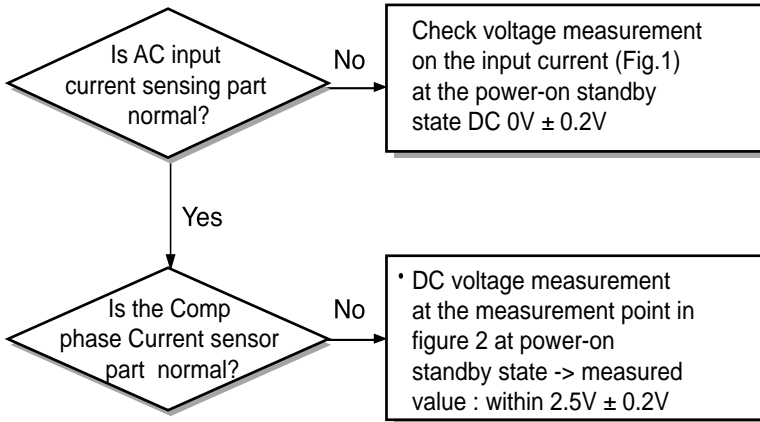

8) CH41/44/45/65: Inv D-Pipe/Outdoor Inlet/Cond. Pipe/Heat sink Sensor Error

| Error Code | Error Detection | Cause of Error | Check Point |
|------------|-------------------------------------|---|--|
| CH41 | Inv D-Pipe sensor open/short | <ul style="list-style-type: none"> • Sensor displacement (poor assembly) • Sensor burned (disconnection, insulation damage) | <ul style="list-style-type: none"> • Check the status of sensor assembly • Check if sensor is burned |
| CH44 | Outdoor Inlet sensor open/short | | |
| CH45 | Cond. Pipe sensor open/short | | |
| CH65 | B/Diode Heat sink sensor open/short | | |

warning Before checking PCB or each outdoor electric parts, wait for 3 minutes after the power is off. When measuring at standby state of power supply, after checking the measurement mode of the meter, be careful of the short-circuits with other parts.

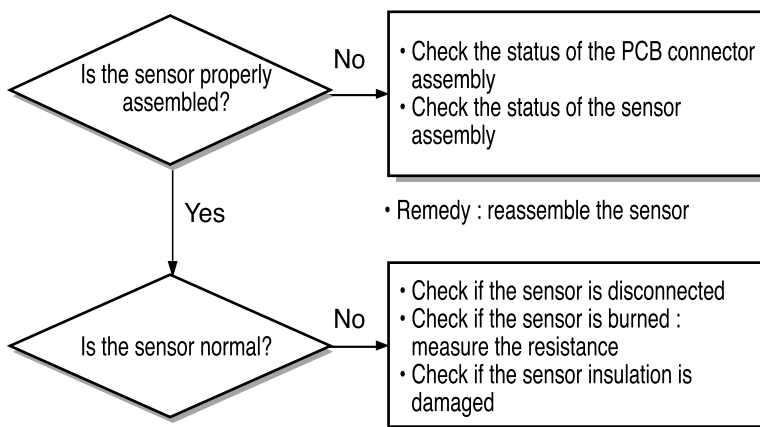

• Inspecting Inverter Compressor Discharge Sensor

1. Set Multi-tester as resistance measurement mode.
2. Measure resistance between the sensor connectors
3. Check if the sensor insulation is damaged -> Measure resistance between sensor connector pin and the unit assembly pipe. (1MΩ or more)

| Sensor Resistance Value (25°C basis) | |
|--------------------------------------|------|
| Inv D-Pipe Sensor | 200k |
| Outdoor Inlet Sensor | 10k |
| Cond. Pipe Sensor | 5k |
| B/Diode Heat Sink Sensor | 10k |

9) CH53: Outdoor Unit <-> Indoor Unit Communication Error

| Error Code | Error Detection | Cause of Error | Check Point |
|------------|--|--|--|
| CH53 | If the data transmitted by the indoor unit is not received for 3 minutes continuously. | <ul style="list-style-type: none"> No power on indoor unit Indoor/outdoor unit Power connection error / communication line not installed Communication error caused by external noise Indoor/outdoor unit communication circuit parts burned | <ul style="list-style-type: none"> Check indoor unit power status Check indoor/outdoor unit power/communication line disconnection Check the status of indoor/outdoor unit ground connections Check if outdoor unit communication parts are burned |

warning

Before checking PCB or each outdoor electric parts, wait for 3 minutes after the power is off. When measuring at standby state of power supply, after checking the measurement mode of the meter, be careful of the short-circuits with other parts.

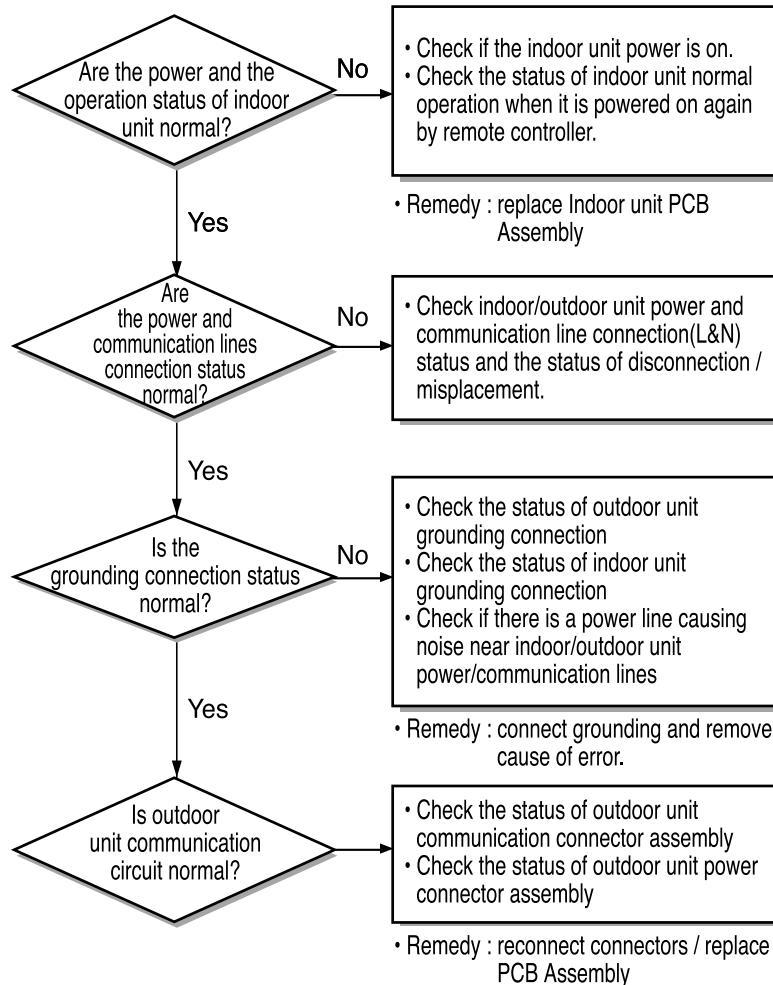

10) CH60: Outdoor Unit PCB EEPROM Error

| Error Code | Error Detection | Cause of Error | Check Point |
|------------|---|---|-----------------|
| CH60 | Incorrect checksum of outdoor unit PCB EEPROM | <ul style="list-style-type: none"> Outdoor unit PCB EEPROM misapplied Outdoor unit PCB EEPROM poor assembly | EEPROM assembly |

warning

Before checking PCB or each outdoor electric parts, wait for 3 minutes after the power is off. When measuring at standby state of power supply, after checking the measurement mode of the meter, be careful of the short-circuits with other parts.

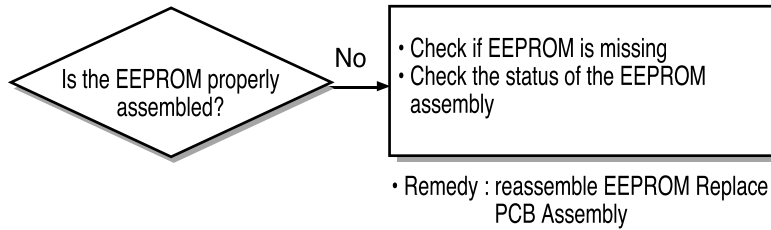

• Inspecting Outdoor EEPROM Assembly Status

1. Check the consistency of the EEPROM's direction inserted in the PCB and the EEPROM marking.

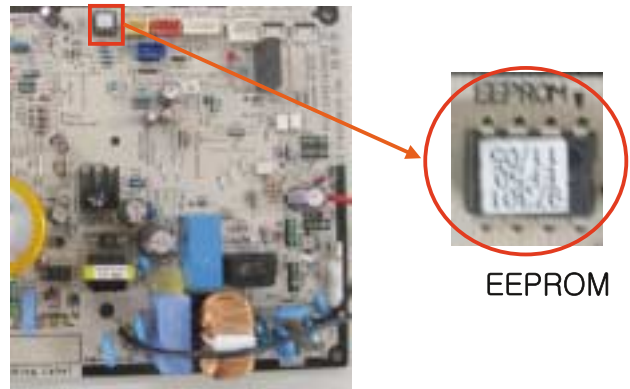

11) CH61: Cond. Pipe Overheat Error

| Error Code | Error Detection | Cause of Error | Check Point |
|------------|--|---|--|
| CH61 | High temperature in outdoor Cond. Pipe | <ul style="list-style-type: none"> • Overload operation (Outdoor fan constraint, screened, blocked) • Outdoor unit heat exchanger contaminated • EEV connector displaced / poor EEV assembly • Poor Cond. Pipe sensor assembly / burned | <ul style="list-style-type: none"> • Check outdoor fan constraint / screened / flow structure • Check if refrigerant overcharged • Check the status of EEV assembly • Check the status of sensor assembly / burn |

warning Before checking PCB or each outdoor electric parts, wait for 3 minutes after the power is off. When measuring at standby state of power supply, after checking the measurement mode of the meter, be careful of the short-circuits with other parts.

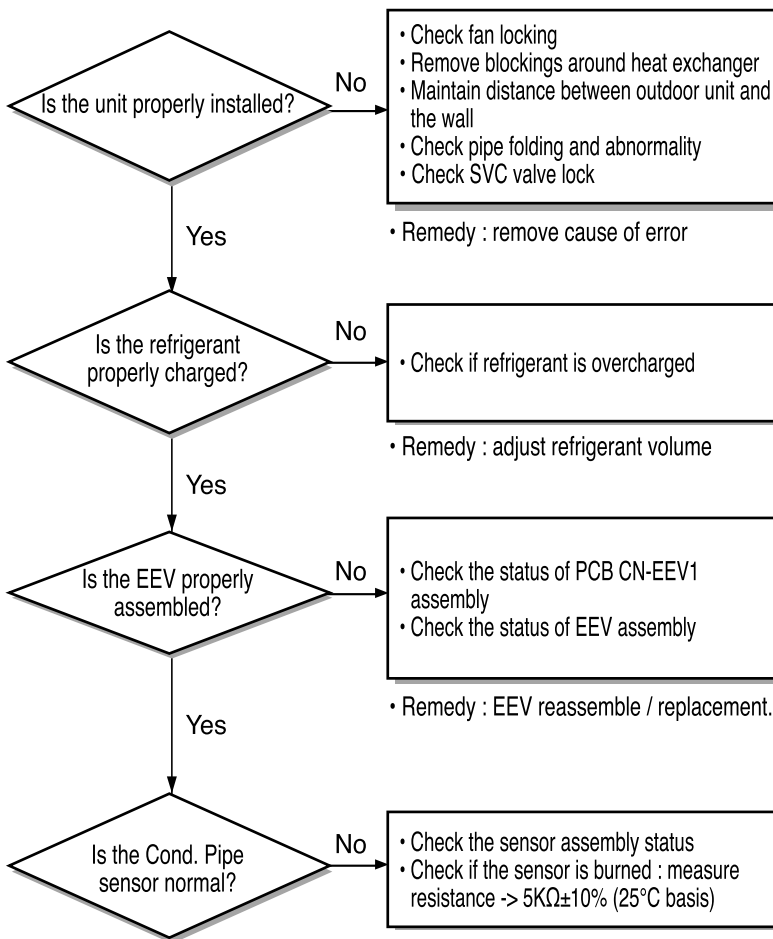

• Inspecting Cond. Pipe Sensor

1. Set Multi-tester as resistance measurement mode.
2. Measure the resistance between rated speed Comp Discharge sensor connector pins.
3. Measure resistance value of $5k\Omega \pm 10\%$, 25°C basis
4. Check if the sensor insulation is damaged. -> measure the resistance between sensor connector pin and unit assembly pipe. ($1M\Omega$ or more)

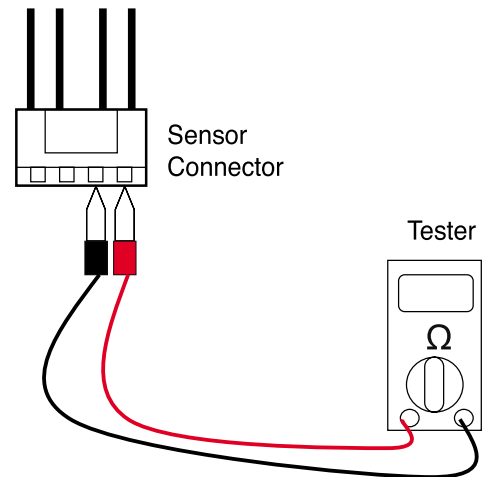

12) CH62: Heat Sink Overheat Error

| Error Code | Error Detection | Cause of Error | Check Point |
|------------|---|---|---|
| CH62 | High temperature in outdoor PCB Heat Sink | <ul style="list-style-type: none"> • Overload operation (Outdoor fan constraint, screened, blocked) • Poor PCB Heat Sink assembly • Poor PCB temperature sensing circuit parts | <ul style="list-style-type: none"> • Check outdoor fan constraint / screened / flow structure • Check for the status of the PCB Heat sink connection • Check PCB temperature sensing parts |

warning Before checking PCB or each outdoor electric parts, wait for 3 minutes after the power is off. When measuring at standby state of power supply, after checking the measurement mode of the meter, be careful of the short-circuits with other parts.

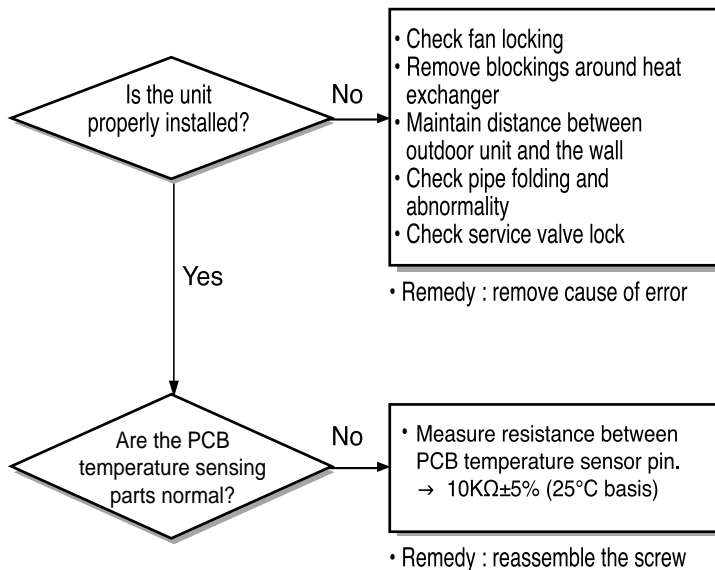

Inspecting PCB temperature sensing part

1. Set Multi-tester as resistance measurement mode.
2. Measure resistance between Heatsink temperature sensor pin.
3. Measured resistance value of $10K\Omega \pm 5\%$, 25°C basis



Heatsink temperature sensor

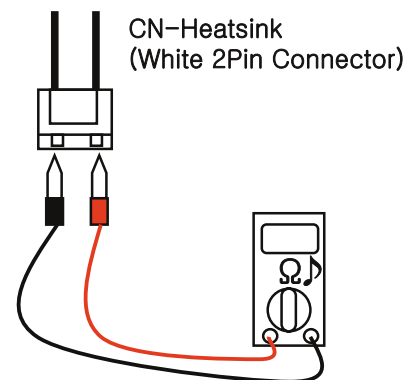

13) CH67: Outdoor BLDC Fan Lock Error

| Error Code | Error Detection | Cause of Error | Check Point |
|------------|--|--|---|
| CH67 | The outdoor unit BLDC Fan operation F/Back signal does not come on | <ul style="list-style-type: none"> Outdoor BLDC Fan Lock PCB Fan connector displaced BLDC Fan motor burned / wire disconnected PCB BLDC Fan operation circuit burned | <ul style="list-style-type: none"> Check for the status of outdoor fan assembly Check for the status of the PCB Fan connector assembly Check Fan motor wire disconnection Check if Fan motor burned |

warning Before checking PCB or each outdoor electric parts, wait for 3 minutes after the power is off. When measuring at standby state of power supply, after checking the measurement mode of the meter, be careful of the short-circuits with other parts.

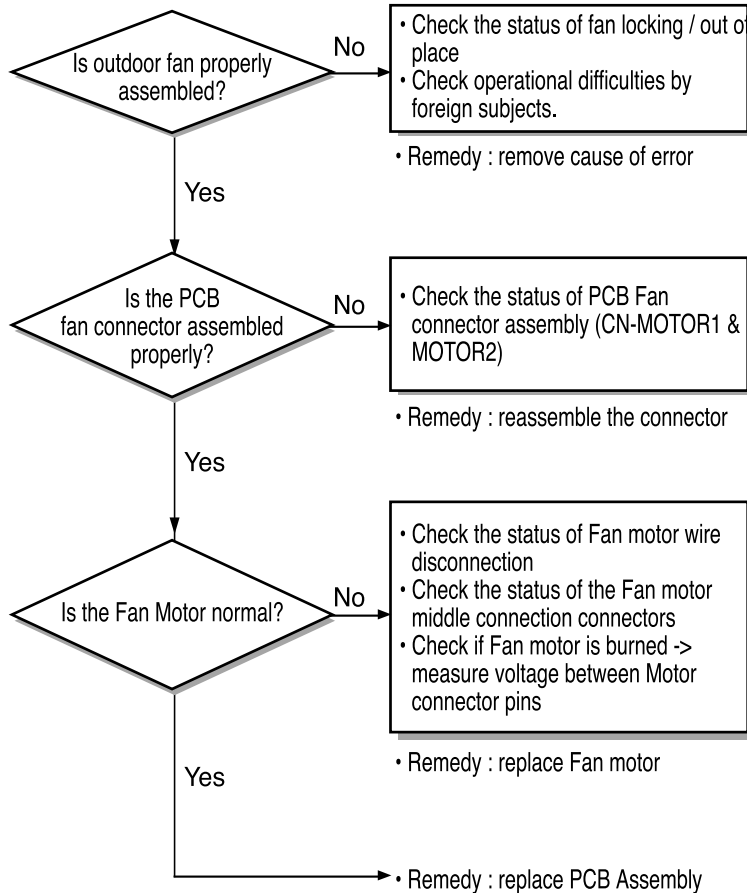

Inspecting Outdoor BLDC Fan Motor burn

- Set Multi-tester as Diode voltage measurement mode.
- Measure voltage between Fan motor connector pin 1 and pin 4 at power off state.
- Measured voltage value of $1V \pm 0.2V$ means the motor is internally burned.

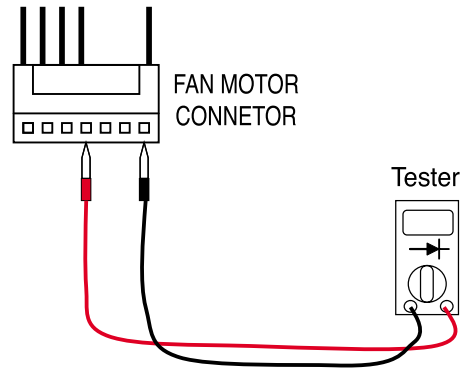



P/NO : MFL41161605

NOVEMBER, 2009