



CONFIDENTIAL

# Multi V Air Conditioner

## SVC MANUAL(Exploded View)

**MODEL : ARNU05GTR\*4  
ARNU07GTR\*4  
ARNU09GTR\*4  
ARNU12GTR\*4  
ARNU15GTR\*4  
ARNU15GTQ\*4  
ARNU18GTQ\*4  
ARNU21GTQ\*4**

### **CAUTION**

Before Servicing the unit, read the safety precautions in General SVC manual.  
Only for authorized service personnel.

Any reproduction, duplication, distribution (including by way of email, facsimile or other electronic means), publication, modification, copying or transmission of this Service Manual is STRICTLY PROHIBITED unless you have obtained the prior written consent of the LG Electronics entity from which you received this Service Manual. The material covered by this prohibition includes, without limitation, any text, graphics or logos in this Service Manual.

Copyright © 2018 LG Electronics Inc. All rights reserved. Only training and service purposes.

# 1. Specification

\* Model Name  
A/B : Basic, C/D : Plasma

Type		4 Way Ceiling Cassette			
Model	Unit	ARNU05GTR*4	ARNU07GTR*4	ARNU09GTR*4	
Cooling Capacity	kW	1.6	2.2	2.8	
	kcal/h	1,400	1,900	2,400	
	Btu/h	5,500	7,500	9,600	
Heating Capacity	kW	1.8	2.5	3.2	
	kcal/h	1,500	2,200	2,800	
	Btu/h	6,100	8,500	10,900	
Casing		Galvanized Steel Plate	Galvanized Steel Plate	Galvanized Steel Plate	
Dimensions (WxDxH)	Body	mm	570 x 570 x 214	570 x 570 x 214	570 x 570 x 214
		inch	22-7/16 x 22-7/16 x 8-7/16	22-7/16 x 22-7/16 x 8-7/16	22-7/16 x 22-7/16 x 8-7/16
	Front Panel	mm	700 x 700 x 22	700 x 700 x 22	700 x 700 x 22
		inch	27-9/16 x 27-9/16 x 7/8	27-9/16 x 27-9/16 x 7/8	27-9/16 x 27-9/16 x 7/8
Coil	Rows x Columns x FPI	1 x 8 x 18	1 x 8 x 18	1 x 8 x 18	
	Face Area	m <sup>2</sup> (ft <sup>2</sup> )	0.21 (2.26)	0.21 (2.26)	0.21 (2.26)
Fan	Type	Turbo Fan	Turbo Fan	Turbo Fan	
	Motor Output x Number	W	43x1	43x1	43 x 1
	Running Current	A	0.2	0.2	0.2
	Air Flow Rate(H/M/L)	CMM	7.5/7.0/6.6	7.5/7.0/6.6	8.2/7.4/6.9
		cfm	265/247/212	265/247/212	289/261/244
	Drive		Direct	Direct	Direct
Motor type		BLDC	BLDC	BLDC	
Temperature Control		Microprocessor, Thermostat for cooling and heating	Microprocessor, Thermostat for cooling and heating	Microprocessor, Thermostat for cooling and heating	
Sound Absorbing Thermal Insulation Material		Foamed polystyrene	Foamed polystyrene	Foamed polystyrene	
Safety Device		Fuse	Fuse	Fuse	
Pipe Connections	Liquid Side	mm(inch)	Ø6.35(1/4)	Ø6.35(1/4)	Ø6.35(1/4)
	Gas Side	mm(inch)	Ø12.7(1/2)	Ø12.7(1/2)	Ø12.7(1/2)
	Drain(ID)	mm(inch)	25(1)	25(1)	25(1)
Net Weight	Body	kg(lbs)	12.6(27.8)	12.6(27.8)	12.6(27.8)
	Packaged	kg(lbs)	15.3(33.7)	15.3(33.7)	15.3(33.7)
Noise Level(Sound Press, 1.5m, H/M/L)		dB(A)+1	36/35/33	36/35/33	35/33/30
Power Supply		Ø, V, Hz	1, 220 ~ 240, 50 1, 220, 60	1, 220 ~ 240, 50 1, 220, 60	1, 220 ~ 240, 50 1, 220, 60
Refrigerant Control			EEV	EEV	EEV
Power cable		mm <sup>2</sup> x No.	CV1.5 x 3C	CV1.5 x 3C	CV1.5 x 3C
Transmission cable		mm <sup>2</sup> x No.	CVV-SB 1.0~1.5 x 2C	CVV-SB 1.0~1.5 x 2C	CVV-SB 1.0~1.5 x 2C
Panel Color			Morning fog	Morning fog	Morning fog
Panel Name(Accessory)			PT-UQC / PT-QCHW0		

## Notes:

- Capacities are based on the following conditions:
  - Cooling
    - Indoor temp. 27°C[80.6°F]DB/ 19°C[66.2°F]WB
    - Outdoor temp. 35°C[95°F]DB/ 24°C[75.2°F]WB
    - Interconnecting Piping Length 7.5m
    - Level Difference of Zero
  - Heating
    - Indoor temp. 20°C[68°F]DB/ 15°C[59°F]WB
    - Outdoor temp. 7°C[44.6°F]DB/ 6°C[42.8°F]WB
    - Interconnecting Piping Length 7.5m
    - Level Difference of Zero

2. Capacities are net capacities

3. Due to our policy of innovation some specifications may be changed without prior notification

4. To be added for more available Models

5. EEV : Electronic Expansion Valve

## Conversion Formula

kcal/h= kW x 860  
Btu/h = kW x 3412  
cfm = m<sup>3</sup>/min x 35.3  
l/s = CMM x 1000/60

\* Model Name  
A/B : Basic, C/D : Plasma

Type		4 Way Ceiling Cassette			
Model	Unit	ARNU12GTR*4	ARNU15GTR*4	ARNU15GTQ*4	
Cooling Capacity	kW	3.6	4.5	4.5	
	kcal/h	3,100	3,900	3,900	
	Btu/h	12,300	15,400	15,400	
Heating Capacity	kW	4.0	5.0	5.0	
	kcal/h	3,400	4,300	4,300	
	Btu/h	13,600	17,100	17,100	
Casing		Galvanized Steel Plate	Galvanized Steel Plate	Galvanized Steel Plate	
Dimensions (WxDxH)	Body	mm	570 x 570 x 214	570 x 570 x 214	570 x 570 x 256
		inch	22-7/16 x 22-7/16 x 8-7/16	22-7/16 x 22-7/16 x 8-7/16	22-7/16 x 22-7/16 x 10-3/32
	Front Panel	mm	700 x 700 x 22	700 x 700 x 22	700 x 700 x 22
		inch	27-9/16 x 27-9/16 x 7/8	27-9/16 x 27-9/16 x 7/8	27-9/16 x 27-9/16 x 7/8
Coil	Rows x Columns x FPI		2 x 8 x 18	2 x 8 x 18	2 x 10 x 18
	Face Area	m <sup>2</sup> (ft <sup>2</sup> )	0.21 (2.26)	0.21 (2.26)	0.27 (2.91)
Fan	Type		Turbo Fan	Turbo Fan	Turbo Fan
	Motor Output x Number	W	43x1	43x1	43x1
	Running Current		A	0.2	0.2
	Air Flow Rate(H/M/L)	CMM	8.7/8.0/7.0	9.2/7.5/7.0	11.0/10.0/9.3
		cfm	307/283/247	325/265/247	388/353/328
	Drive		Direct	Direct	Direct
Motor type		BLDC	BLDC	BLDC	
Temperature Control		Microprocessor, Thermostat for cooling and heating	Microprocessor, Thermostat for cooling and heating	Microprocessor, Thermostat for cooling and heating	
Sound Absorbing Thermal Insulation Material		Foamed polystyrene	Foamed polystyrene	Foamed polystyrene	
Safety Device		Fuse	Fuse	Fuse	
Pipe Connections	Liquid Side	mm(inch)	Ø6.35(1/4)	Ø6.35(1/4)	Ø6.35(1/4)
	Gas Side	mm(inch)	Ø12.7(1/2)	Ø12.7(1/2)	Ø12.7(1/2)
	Drain(ID)	mm(inch)	25(1)	25(1)	25(1)
Net Weight	Body	kg(lbs)	13.7(30.2)	13.7(30.2)	15.0(33.1)
	Packaged	kg(lbs)	16.4(36.2)	16.4(36.2)	17.9(39.5)
Noise Level(Sound Press, 1.5m, H/M/L)		dB(A)+1	36/35/34	39/35/32	37/36/35
Power Supply	Ø, V, Hz		1, 220 ~ 240, 50	1, 220 ~ 240, 50	1, 220 ~ 240, 50
			1, 220, 60	1, 220, 60	1, 220, 60
Refrigerant Control		EEV	EEV	EEV	
Power cable	mm <sup>2</sup> x No.	CV1.5 x 3C	CV1.5 x 3C	CV1.5 x 3C	
Transmission cable	mm <sup>2</sup> x No.	CVV-SB 1.0~1.5 x 2C	CVV-SB 1.0~1.5 x 2C	CVV-SB 1.0~1.5 x 2C	
Panel Color		Morning fog	Morning fog	Morning fog	
Panel Name(Accessory)		PT-UQC / PT-QCHW0			

**Notes:**

- Capacities are based on the following conditions:
  - Cooling
    - Indoor temp. 27°C[80.6°F]DB/ 19°C[66.2°F]WB
    - Outdoor temp. 35°C[95°F]DB/ 24°C[75.2°F]WB
    - Interconnecting Piping Length 7.5m
    - Level Difference of Zero
  - Heating
    - Indoor temp. 20°C[68°F]DB/ 15°C[59°F]WB
    - Outdoor temp. 7°C[44.6°F]DB/ 6°C[42.8°F]WB
    - Interconnecting Piping Length 7.5m
    - Level Difference of Zero

**Conversion Formula**

kcal/h= kW x 860  
Btu/h = kW x 3412  
cfm = m<sup>3</sup>/min x 35.3  
l/s = CMM x 1000/60

- Capacities are net capacities
- Due to our policy of innovation some specifications may be changed without prior notification
- To be added for more available Models
- EEV : Electronic Expansion Valve

\* Model Name  
A/B : Basic, C/D : Plasma

Type			4 Way Ceiling Cassette	
Model		Unit	ARNU18GTQ*4	ARNU21GTQ*4
Cooling Capacity		kW	5.6	6.0
		kcal/h	4,800	5,100
		Btu/h	19,100	20,500
Heating Capacity		kW	6.3	6.8
		kcal/h	5,400	5,800
		Btu/h	21,500	23,200
Casing			Galvanized Steel Plate	Galvanized Steel Plate
Dimensions (WxDxH)	Body	mm	570 x 570 x 256	570 x 570 x 256
		inch	22-7/16 x 22-7/16 x 10-3/32	22-7/16 x 22-7/16 x 10-3/32
	Front Panel	mm	700 x 700 x 22	700 x 700 x 22
		inch	27-9/16 x 27-9/16 x 7/8	27-9/16 x 27-9/16 x 7/8
Coil	Rows x Columns x FPI		2 x 10 x 18	2 x 10 x 18
	Face Area	m <sup>2</sup> (ft <sup>2</sup> )	0.27 (2.91)	0.27 (2.91)
Fan	Type		Turbo Fan	Turbo Fan
	Motor Output x Number	W	43x1	43x1
	Running Current		A	0.2
	Air Flow Rate(H/M/L)	CMM	11.2/11.0/10.0	12.0/11.1/9.4
		cfm	396/388/353	424/392/332
	Drive		Direct	Direct
Motor type		BLDC	BLDC	
Temperature Control			Microprocessor, Thermostat for cooling and heating	Microprocessor, Thermostat for cooling and heating
Sound Absorbing Thermal Insulation Material			Foamed polystrene	Foamed polystrene
Safety Device			Fuse	Fuse
Pipe Connections	Liquid Side	mm(inch)	Ø6.35(1/4)	Ø9.52(3/8)
	Gas Side	mm(inch)	Ø12.7(1/2)	Ø15.88(5/8)
	Drain(ID)	mm(inch)	25(1)	25(1)
Net Weight	Body	kg(lbs)	15.0(33.1)	15.0(33.1)
	Packaged	kg(lbs)	17.9(39.5)	17.9(39.5)
Noise Level(Sound Press, 1.5m, H/M/L)		dB(A)+1	38/37/36	42/40/35
Power Supply	Ø, V, Hz		1, 220 ~ 240, 50	1, 220 ~ 240, 50
			1, 220, 60	1, 220, 60
Refrigerant Control			EEV	EEV
Power cable	mm <sup>2</sup> x No.		CV1.5 x 3C	CV1.5 x 3C
Transmission cable	mm <sup>2</sup> x No.		CVV-SB 1.0~1.5 x 2C	CVV-SB 1.0~1.5 x 2C
Panel Color			Morning fog	Morning fog
Panel Name(Accessory)			PT-UQC / PT-QCHW0	

**Notes:**

- Capacities are based on the following conditions:
  - Cooling
    - Indoor temp. 27°C[80.6°F]DB/ 19°C[66.2°F]WB
    - Outdoor temp. 35°C[95°F]DB/ 24°C[75.2°F]WB
    - Interconnecting Piping Length 7.5m
    - Level Difference of Zero
  - Heating
    - Indoor temp. 20°C[68°F]DB/ 15°C[59°F]WB
    - Outdoor temp. 7°C[44.6°F]DB/ 6°C[42.8°F]WB
    - Interconnecting Piping Length 7.5m
    - Level Difference of Zero

- Capacities are net capacities
- Due to our policy of innovation some specifications may be changed without prior notification
- To be added for more available Models
- EEV : Electronic Expansion Valve

**Conversion Formula**

kcal/h= kW x 860  
Btu/h = kW x 3412  
cfm = m<sup>3</sup>/min x 35.3  
l/s = CMM x 1000/60

## 2. List of Functions

Category	Function	ARNU05GTR*4 / ARNU07GTR*4 / ARNU09GTR*4 ARNU12GTR*4 / ARNU15GTR*4 / ARNU15GTQ*4 ARNU18GTQ*4 / ARNU21GTQ*4
Air flow	Air supply outlet	4
	Airflow direction control(left & right)	-
	Airflow direction control(up & down)	auto
	Auto swing(left & right)	-
	Auto swing(up & down)	O
	Airflow steps(fan/cool/heat)	4/5/4
	Chaos swing	X
	Chaos wind(auto wind)	O
	Jet cool(Power wind)	O
	Swirl wind	O
Air purifying	Deodorizing filter	X
	Plasma air purifier	Option
	Prefilter(washable / anti-fungus)	O
Installation	Drain pump	O
	E.S.P. control	O
	Electric heater(operation)	X
	High ceiling operation	O
Reliability	Hot start	O
	Self diagnosis	O
	Soft dry operation	O
Convenience	Auto changeover	O(Only heat recovery)
	Auto cleaning	X
	Auto operation(artificial intelligence)	O(Heat pump or cooling only)
	Auto restart operation	O
	Child lock	O
	Forced operation	O
	Group control	O
	Sleep mode	O
	Timer(on/off)	O
	Timer(weekly)	O
	Two thermistor control	O
Elevation Grill(Accessory)	X	
Individual control	Standard wired remote controller	Accessory
	Deluxe wired remote controller	Accessory
	Simple wired remote controller	Accessory
	Wired remote controller(for hotel use)	Accessory
	Wireless remote controller(simple)	X
	Wireless LCD remote control	Accessory
Special function kit	Zone control	-
	CTIE	-
	Electro thermostat	-

O : Applied    X : Not applied    - : No relation

Option : Model name & price are different according to options, and assembled in factory with main unit.

Accessory : Installed at field, ordered and purchased separately by the corresponding model name, supplied with separate package.

### 3. Piping Diagrams

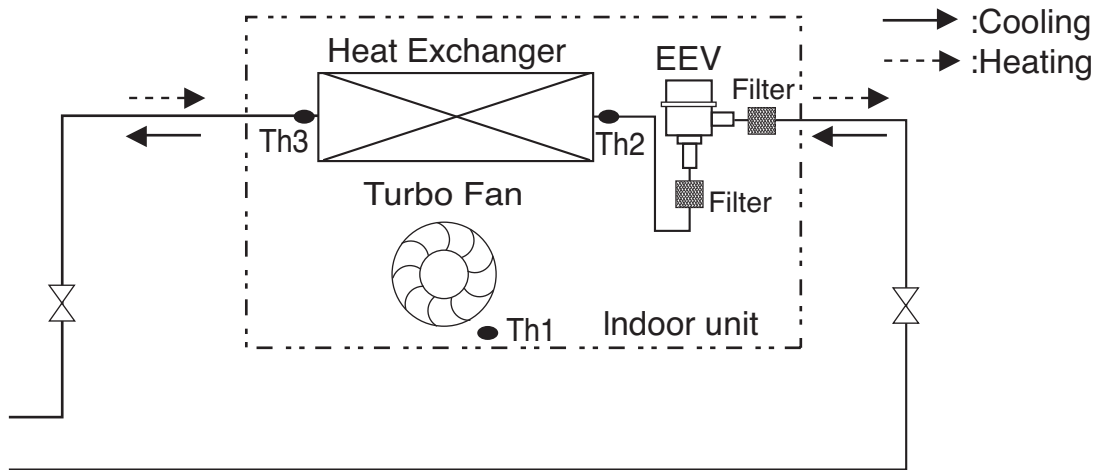

Refrigerant pipe connection port diameter

[unit: mm(inch)]

Model	Gas	Liquid
ARNU05GTR*4	Ø12.7(1/2)	Ø6.35(1/4)
ARNU07GTR*4	Ø12.7(1/2)	Ø6.35(1/4)
ARNU09GTR*4	Ø12.7(1/2)	Ø6.35(1/4)
ARNU12GTR*4	Ø12.7(1/2)	Ø6.35(1/4)
ARNU15GTR*4	Ø12.7(1/2)	Ø6.35(1/4)
ARNU15GTQ*4	Ø12.7(1/2)	Ø6.35(1/4)
ARNU18GTQ*4	Ø12.7(1/2)	Ø6.35(1/4)
ARNU21GTQ*4	Ø15.88(5/8)	Ø9.52(3/8)

LOC.	Description	PCB Connector (Color)
Th1	Thermistor for room air temperature	CN-ROOM (Yellow)
Th2	Thermistor for pipe in temperature	CN-PIPE_IN (White)
Th3	Thermistor for pipe out temperature	CN-PIPE_OUT (Red)

# 4. Wiring Diagrams

## TR/TQ Chassis

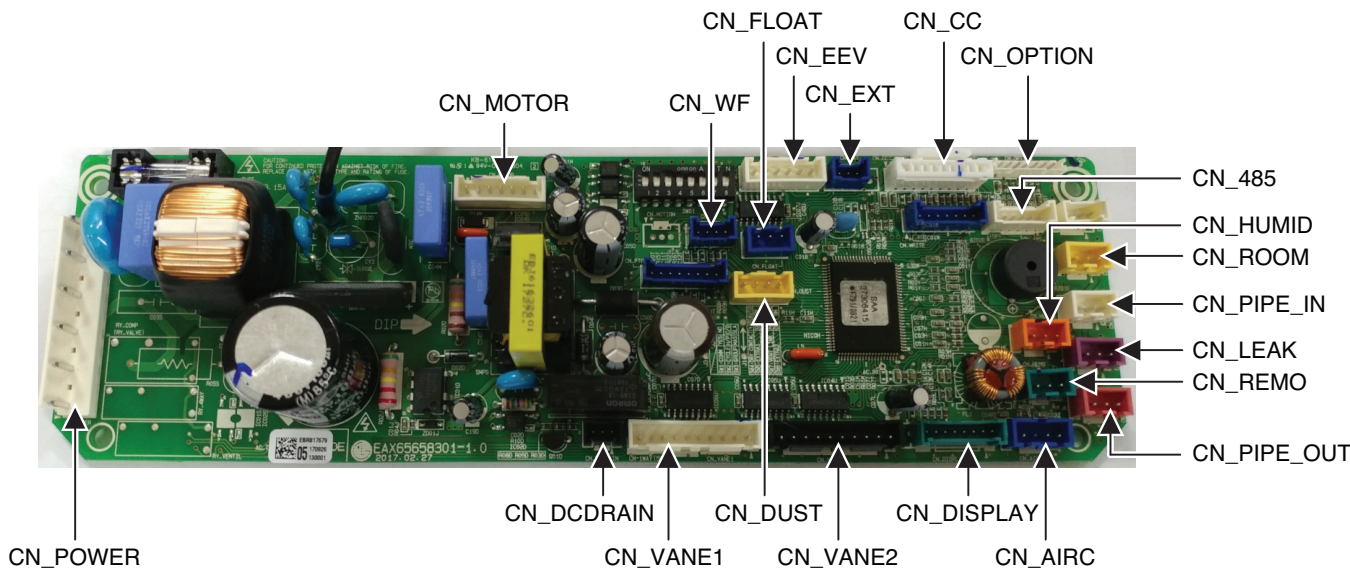
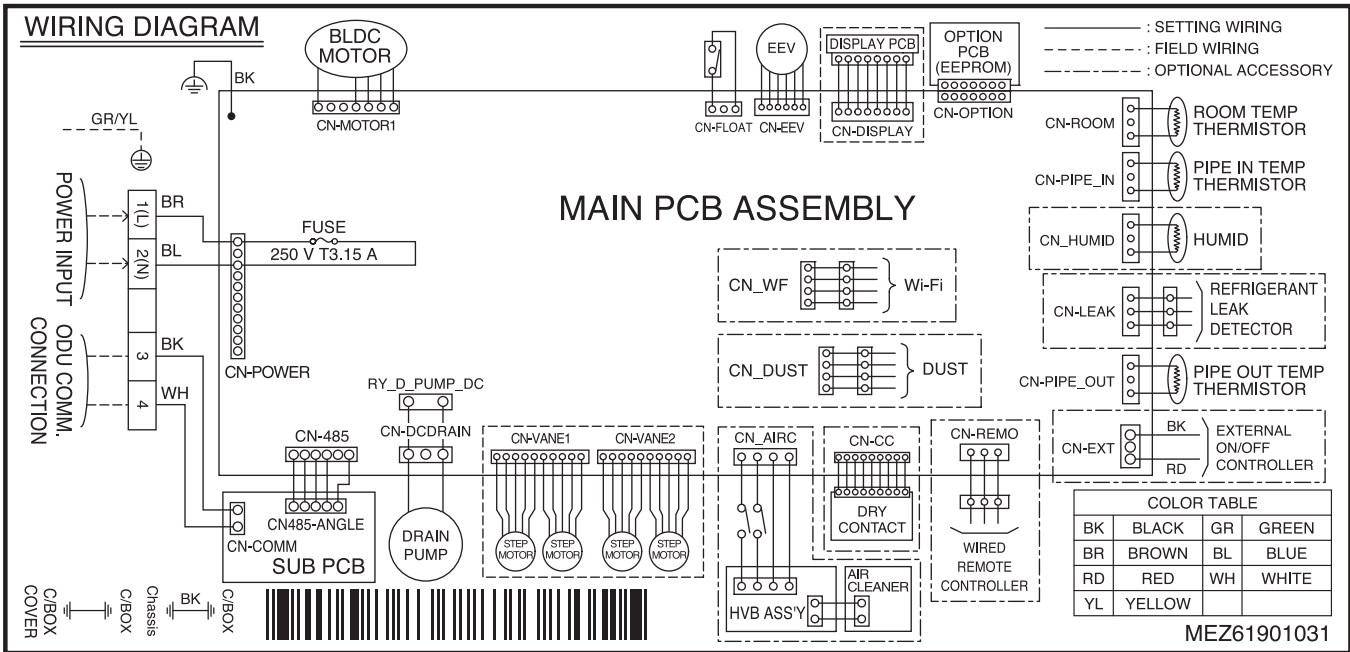

## 5. DIP Switch Setting

### 1. Indoor Unit

	Function	Description	Setting Off	Setting On	Default
SW1	Communication	N/A (Default)	-	-	Off
SW2	Cycle	N/A (Default)	-	-	Off
SW3	Group Control	Selection of Master or Slave	Master	Slave	Off
SW4	Dry Contact Mode	Selection of Dry Contact Mode	Wired/Wireless remote controller Selection of Manual or Auto operation Mode	Auto	Off
SW5	Installation	Fan continuous operation	Continuous operation Removal	-	Off
SW6	Heater linkage	N/A	-	-	Off
SW7	Ventilator linkage	Selection of Ventilator linkage	Linkage Removal	Working	Off
	Vane selection (Console)	Selection of up/down side Vane	Up side + Down side Vane	Up side Vane Only	
	Region selection	Selection tropical region	General model	Tropical model	
SW8	Etc.	Spare	-	-	Off

### **⚠ CAUTION**

For Multi V Models, DIP switch 1, 2, 6, 8 must be set OFF.

### 2. Outdoor Unit

In case that the products meet specific conditions, "Auto addressing" function can start automatically with the improved speed by turning the DIP switch #3 of the outdoor unit and resetting the power.

\* Specific conditions:

- All names of the indoor units are ARNU\*\*\*\*4.
- The serial number of Multi V super IV (outdoor units) is after October 2013.

DIP switch 7 segment



Outdoor Unit PCB

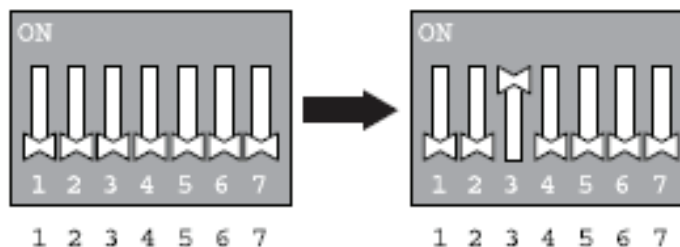

Outdoor Unit DIP Switch



## 6. Exploded View TR/TQ(Standard model)

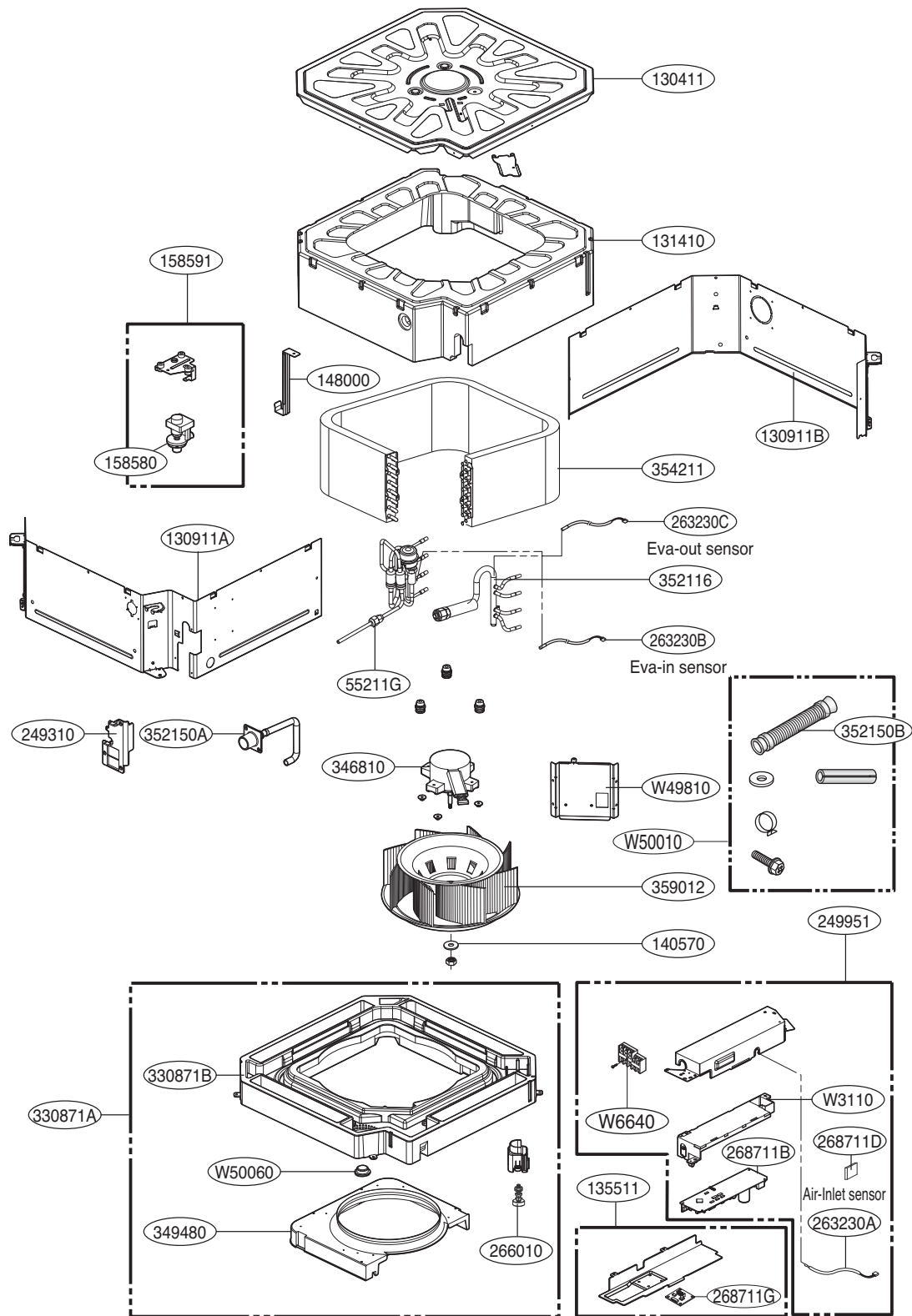

LOC.	SVC No.	Description	PCB Connector (Color)
Th1	263230A	Thermistor for room air temperature	CN-ROOM (Yellow)
Th2	263230B	Thermistor for pipe in temperature	CN-PIPE_IN (White)
Th3	263230C	Thermistor for pipe out temperature	CN-PIPE_OUT (Red)

## 6. Exploded View TR/TQ(Plasma model)

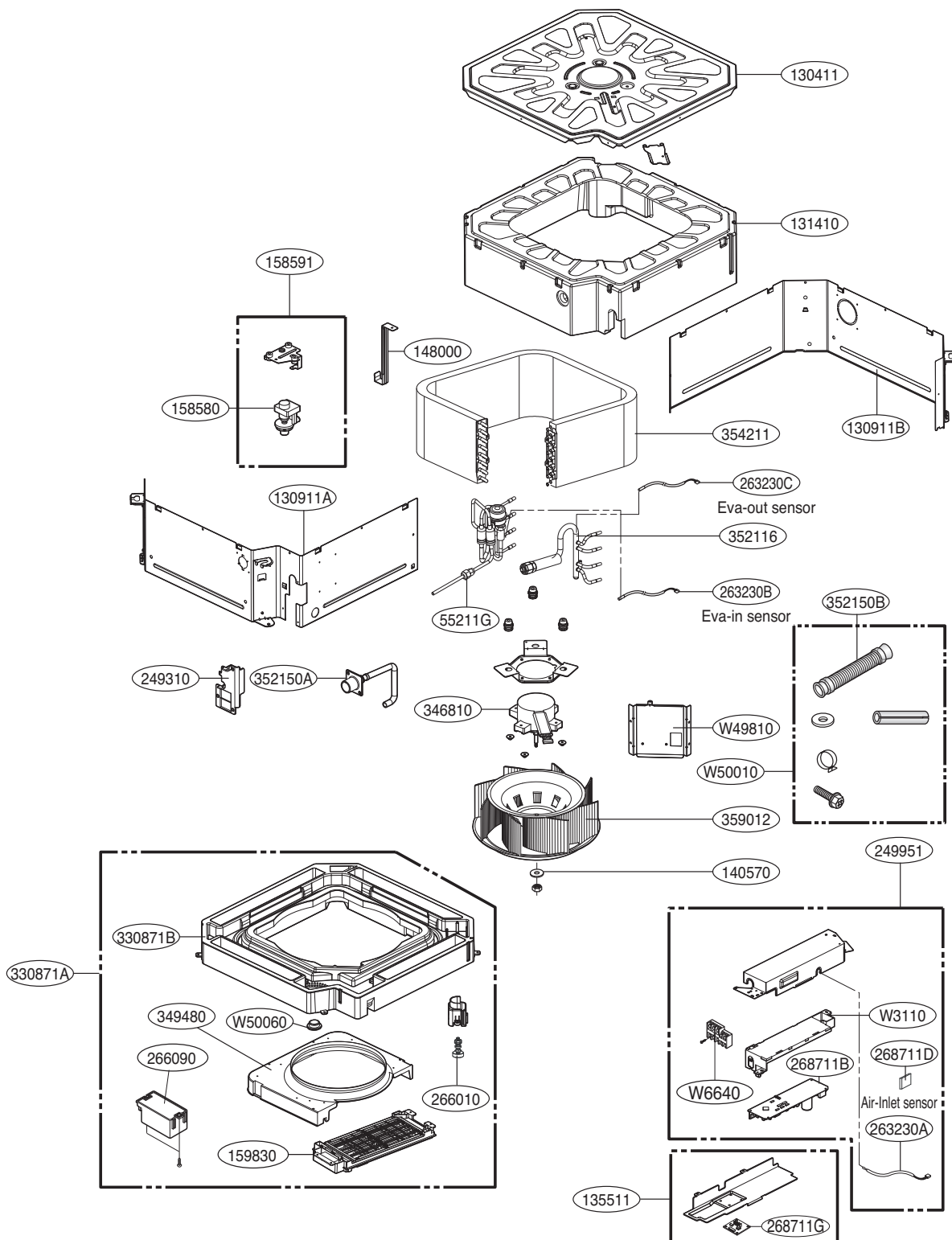

LOC.	SVC No.	Description	PCB Connector (Color)
Th1	263230A	Thermistor for room air temperature	CN-ROOM (Yellow)
Th2	263230B	Thermistor for pipe in temperature	CN-PIPE_IN (White)
Th3	263230C	Thermistor for pipe out temperature	CN-PIPE_OUT (Red)

## 7. Self-diagnosis function

### Error Indicator

- This function indicates types of failure in self-diagnosis and occurrence of failure for air condition.
- Error mark is displayed on display window of indoor units and wired remote controller, and 7-segment LED of outdoor unit control board as shown in the table.
- If more than two troubles occur simultaneously, lower number of error code is first displayed.
- After error occurrence, if error is released, error LED is also released simultaneously.

### Error Display

- 1st,2nd,3rd LED of 7-segment indicates error number, 4th LED indicates unit number. Indicates unit number.  
(\* = 1:Master, 2 : Slave 1, 3 : Slave 2)

Ex) 211 : No.21 error of master unit  
 213 : No.21 error of slave2  
 1051 : No.105 error of master unit

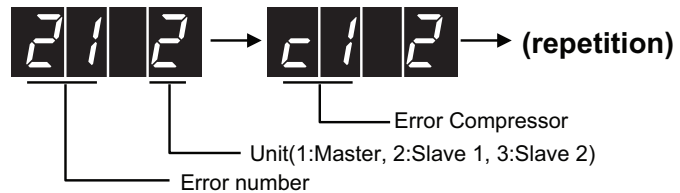

※ Refer to the DX-Ventilation manual for DX-Ventilation error code

Display			Title	Cause of Error	
Indoor unit related error	0	1	-	Air temperature sensor of indoor unit	Air temperature sensor of indoor unit is open or short
	0	2	-	Inlet pipe temperature sensor of indoor unit	Inlet pipe temperature sensor of indoor unit is open or short
	0	3	-	Communication error : wired remote controller ↔ indoor unit	Failing to receive wired remote controller signal in indoor unit PCB
	0	4	-	Drain pump	Malfunction of drain pump
	0	5	-	Communication error : Indoor communication PCB ↔ indoor unit	Indoor Unit PCB did not receive signal from Indoor communication PCB for over 3 minutes continuously
	0	6	-	Outlet pipe temperature sensor of indoor unit	Outlet pipe temperature sensor of indoor unit is open or short
	0	9	-	Indoor EEPROM Error	In case when the serial number marked on EEPROM of Indoor unit is 0 or FFFFFF
	1	0	-	Poor fan motor operation	Disconnecting the fan motor connector / Failure of indoor fan motor lock
	2	3	0	Refrigerant leakage sensing error	Refrigerant leakage sensing error and sensor defect error
	2	3	7	Communication defect in indoor communication PCB ↔ outdoor communication PCB	Indoor communication PCB did not receive signal from outdoor communication PCB for over 3 minutes continuously
	2	3	8	Communication error in outdoor communication PCB ↔ outdoor unit	Outdoor communication PCB did not receive communication signal from outdoor unit for over 3 minutes continuously



P/NO : MFL68506012

January, 2018